

QUEST

Operation and Service Manual



COPYRIGHT 1983
by SIMUTREK INCORPORATED
ALL RIGHTS RESERVED
925 East Brokaw Road
San Jose, CA 95131
(408) 291-2000

TABLE OF CONTENTS

OPERATOR SETUP PROCEDURE.....	1.0
OPERATOR OPTIONS.....	2.0
Test Mode.....	2.1
Hardware Diagnostics.....	2.2
Coinage Settings.....	2.3
Free Play.....	2.3
Parameters.....	2.4
Bonus Settings.....	2.5
Coin Audit Totals.....	2.6
Game Audit Totals.....	2.6
Bonus Audit Totals.....	2.6
Cubic History.....	2.6
TECHNICAL INFORMATION SECTION	
System Block Diagram.....	3.0
Functions of PC Boards.....	3.1
Schematics:	
Mother/Sounds PC Board.....	4.0
Rotate/Video PC Board.....	4.1
Line Drawer PC Board.....	4.2
Fill PC Board.....	4.3
EPROM PC Board.....	4.4
I/O PC Board.....	4.5
Audio Power Amp PC Board.....	4.6
Harnessing.....	4.7

Assembly Diagrams:

Mother/Sounds PC Board.....	5.0
Rotate/Video PC Board.....	5.1
Line Drawer PC Board.....	5.2
Fill PC Board.....	5.3
EPROM PC Board.....	5.4
I/O PC Board.....	5.5
Audio Power Amp PC Board.....	5.6
Game Cabinet.....	5.7

Part Lists:

Mother/Sounds PC Board.....	6.0
Rotate/Video PC Board.....	6.1
Line Drawer PC Board.....	6.2
Fill PC Board.....	6.3
EPROM PC Board.....	6.4
I/O PC Board.....	6.5
Audio Power Amp PC Board.....	6.6
Harnesses.....	6.7
Miscellaneous.....	6.8

POWER SUPPLY INFORMATION.....	7.0
-------------------------------	-----

CUSTOMER ASSISTANCE

WATS Line Telephone Number.....	9.1
---------------------------------	-----

Service Publication Mailing List.....	9.1
---------------------------------------	-----

GENERAL SPECIFICATIONS.....	9.1
-----------------------------	-----

OPERATOR SETUP PROCEDURE

After removal from the shipping carton, please inspect the game thoroughly, both inside and outside, to be sure there has been no shipping damage, and that all internal assemblies remain secure. Then follow the procedure below.

1. Remove the back door.
1. Disconnect the shipping straps securing the video disk player.
3. Carefully slide the disk player platform as far out as it will go.
4. Skip steps 5, 6 and 7 if you have purchased an upright model without a seat.
5. Disconnect the wiring harnesses from the disk player, noting where they are plugged into the player. Lift the player up off its mounts, and set it safely aside.
6. Mount the seat assembly, making sure to connect the wiring harness in the seat assembly before bolting the seat onto the cabinet.
7. Reconnect the wiring harnesses to the disk player, and reinstall the player on its mounts.
8. Apply proper AC power to the game cabinet, and pull the interlock switch out to the service position.
9. Turn on the disk player power switch.
10. Press the EJECT (OR REJECT) button on the disk player. This may need to be done more than once, in order to unlock the top lid of the player.
11. Lift the top lid of the player.
12. To prevent possible damage to the internal mechanism of the disk player during shipment, a shipping screw is placed beside the center shaft at the factory (see Fig. 1). It is necessary now to remove the screw, together with the screw plate below it. Next, remove the gray lens cap which is placed over the lens (just to the right of the center shaft) to protect the lens from dust and dirt during shipment. (see Fig. 1).

NOTE: Store the shipping screw, plate, and lens cap with the operating instructions in case the player has to be moved or shipped again.

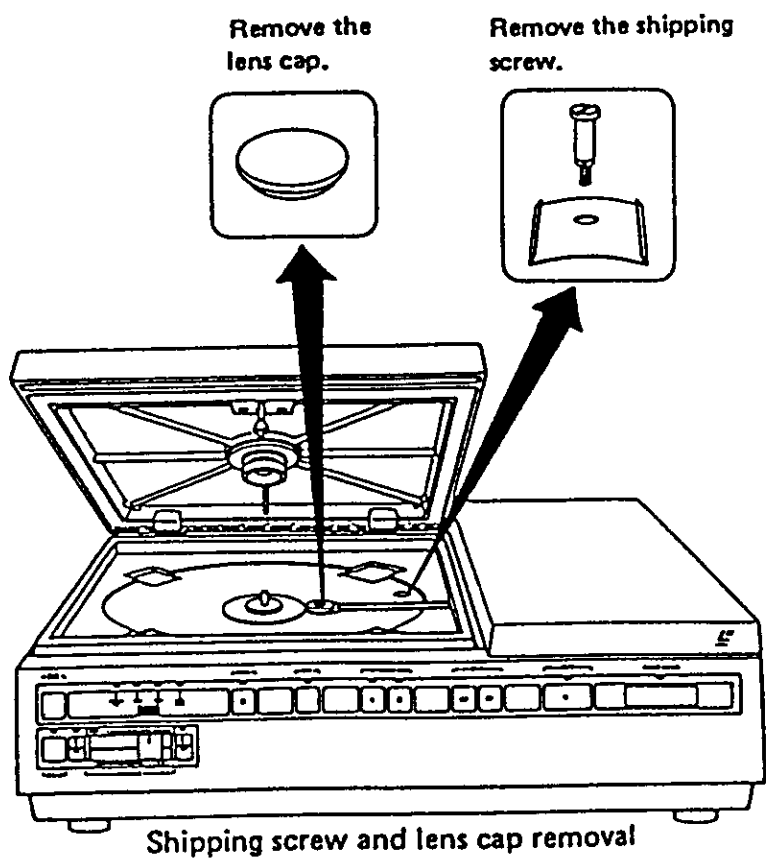

FIG. 1

13. Install the laser disk on the turntable, making sure you put the correct side down.
14. Close the player lid, pressing down until it clicks shut.
15. Slide the player back into position in the cabinet, and reconnect the shipping straps, but do not tighten them. Leave them loose enough for the shock mounts to function properly.
16. Reinstall the back door of the cabinet.
17. The game should now be ready to play. After applying power, give the game time to warm up and reset both the real-time hardware and video disk. This usually takes less than a minute, but can take as long as two.
18. To make any adjustments, check or change coinage settings, or run hardware self-diagnostics, refer to the section on the TEST MODE.

NOTE: During initial seconds of power-up and some sections of the TEST MODE there will be garbled audio and video. This is normal and acceptable, unless it lasts longer than a few seconds.

If at any time the game needs to be moved any distance, or shipped anywhere, you MUST be sure to do the following to protect the disk player and disk:

1. Apply power to the player to open the top.
2. Remove and separately package the video disk.
3. Reinstall the objective lens cover, and the shipping screw and plate.
4. Close the top of the player and turn off game power.
5. Tighten the shipping straps securing the player, so it can't bounce around on the shock absorbers during shipment.

After the move or shipment, repeat the original setup procedure.

OPERATOR OPTIONS

CUBE QUEST allows the operator or distributor to make use of the following options:

- Hardware diagnostic programs
- Programmable coinage settings
- Programmable game play parameters
- Programmable bonus settings
- Coin audit totals; timed (i.e. short term accounting)
- Coin audit totals; permanent (i.e. long term accounting)
- Game (play) audit totals; timed
- Game audit totals; permanent
- Bonus audit totals; timed
- Bonus audit totals; permanent
- Top ten high score history
- Free play mode
- Free credit switch (for individual free games while in normal play mode)

More detailed information concerning these features can be found in the section titled TEST MODE.

TEST MODE

The TEST MODE is the key to a host of valuable tests, adjustments, and accounting functions available in Cube Quest. Just press the TEST switch, and the TEST MODE begins.

Now you can use the RIGHT SIDE FIRE BUTTON on the game control panel to step through the various sections of the TEST MODE in sequence. You may elect to execute or bypass whichever sections you choose, and you may use the LEFT SIDE FIRE BUTTON to step backward to a section you may have passed.

Each time the FIRE button is pressed you are presented with a list of individual functions which are then currently accessible. For example, under HARDWARE DIAGNOSTICS there are:

Alignment Test	ROM Test
Color Bar Test	RAM Test
Switch Test	Sound Test
Battery Reset Test	Disk Test

Now you may select from among these items, by pressing the CUBE BUTTON. The item selected will change color (from white to green). Each time you press the CUBE button, the next item will be selected. Should you choose to execute any of the "tests" shown (or access any information or settings indicated), simply press the TEST button again. After executing one of these functions, you may get back to the list (or menu) of items by once more pressing the TEST button.

In selections where your purpose is to alter settings, such as coinage, you use the TRACKBALL to change the number which you have selected with the CUBE button.

In selections that are purely informational, such as auditing functions, you have available two types of information; timed and permanent. This means that the game records statistics both since the last time the figures were purposely reset and also since the game was first powered up (or the last time there was a battery failure). In effect this gives you both short term and long term information about the play of the game simultaneously.

The following pages describe some of the things you should know about the individual sections of the TEST MODE.

In summary, uses of the controls in the TEST MODE are:

TEST switch	- Used to start TEST MODE, start and stop selected tests.
RIGHT FIRE button	- Used to step FORWARD through test categories.
LEFT FIRE button	- Used to step BACKWARD through test categories.
CUBE button	- Used to select individual tests.
TRACKBALL	- Used to change settings.

6. Adjust TINT Pot R30 to match shades of blue squares and violet squares between disk video and the upper row of hardware generated video. The upper row of hardware generated video is 75% saturation, as is the disk video, so they can match closely. The second row from the top of real-time hardware video is brighter (100% saturation) than the disk generated video, and cannot therefore be accurately used to adjust the disk video.

SWITCH TEST

PURPOSE: To test control panel switches, trackball, coin mech switches, tilt (anti-slam) switch, if included, and Free credit switch.

REMARKS: Color change indicates state of switch (OPEN or CLOSED), and of optical sensors on trackball (HIGH or LOW). HEXI-DECIMAL Digits indicate clock and data outputs from trackball (HC=Horizontal Clock, HD=Horizontal Data, VC=Vertical Clock, VD=Vertical Data).

NOTE:

An LED array, located on the I/O PC Board inside the upper coin door, cycles through each segment during this test. Normally, segment #1 indicates battery failure, segment #2 indicates bad coin, segment #3 indicates the game thinks there is no laser disk unit, segment #'s 4 - 9 have no function, segment #10 indicates logic power on.

BATTERY RESET TEST

PURPOSE: To simulate a battery failure in order to reset all options to factory settings.

REMARKS: Text on screen changes color to acknowledge reset.

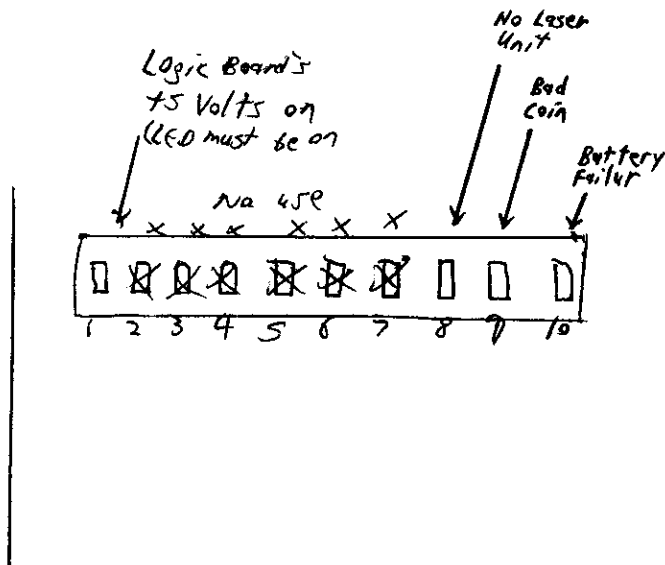

HARDWARE DIAGNOSTICS (cont'd)

ROM TEST

PURPOSE: Adds up data in all addresses of each ROM to compare to known checksum. Writes "GOOD" if checksum equal, writes incorrect number if not equal. "L" indicates low order byte. "H" indicates high order byte.

ROMS can be located on the EPROM PC Board using following table:

<u>Test Screen Designation</u>	<u>Location on PCB</u>
0 -----	1A
1 -----	1B
2 -----	2A
3 -----	2B
4 -----	3A
5 -----	3B
6 -----	4A
7 -----	4B
8 -----	5A
9 -----	5B
A -----	6A
B -----	6B
C -----	7A
D -----	7B
E -----	8A
F -----	8B

RAM TEST

PURPOSE: Checks all Data Paths, Address Paths, Battery RAM, Game RAM, Rotate RAM.

REMARKS: If any Data or Address Paths are bad, error code is displayed. If any RAM is bad, general location is displayed.

SOUND TEST

PURPOSE: Checks all sound channels for output.

REMARKS: LEFT FIRE button cycles through descending tones, RIGHT FIRE button cycles through ascending tones. Each tone is generated through a separate channel (there are 16 channels). Please observe clarity of tone. Unclear tone may indicate a problem. EVEN channels should come out LEFT speaker and ODD channels should come out right speaker.

DISK TEST

To check laser

PURPOSE: To test all disk access functions, such as Frame seek, high speed search, skip forward, skip backward, and select any disk video desired for display by frame number.

DISK TEST (Cont'd)

REMARKS: Use the CUBE button to select desired function, use FIRE button(s) to execute. Selected text or numbers change from white to green while selected.

TOGGLE FRAME WINDOW turns on and off a video display of disk frame number currently being viewed.

SEEK TEST causes disk to do high speed search and frame seek continuously until FIRE button is again pressed to halt the test.

SEARCH TO FRAME NUMBER allows you to select a particular frame number for viewing. Use the TRACKBALL to select the desired frame number.

SKIP FORWARD lets you select the number of frames you would like to skip over in a Forward direction, each time you press the FIRE button.

SKIP BACK is the same as skip forward, except in the reverse direction.

NOTE: While disk is searching, text on screen will so indicate, with red word "SEARCHING", located just below words "DISK READY" (in green).

COINAGE SETTINGS

Individual settings are allowed here for Left, Right, and Center (if used) coin mechanisms. In all cases you may set any number of coins (up to 15) for any number of credits (up to 15).

You may also elect for bonus credits if desired, and/or minimum number of coins required for credit.

Use the TRACKBALL for changing numbers, and the CUBE button to select which numbers are to be changed.

FREE PLAY:

Setting ANY "coins" reading to a zero puts the game into the FREE PLAY mode.

If only a few free credits are desired, use the credit switch inside the upper coin door, located next to the TEST switch.

PARAMETERS

In this section of the TEST MODE you are able to change various characteristics of game play. Brief explanations follow:

ITEM	FACTORY SET	REMARKS
Number ships	3	Sets # of ships per player per game
Mutha	3	Sets # of evil creatures per game (only for 3 CUBE)
Cor Sel	1	0 = No time limit to select a corridor 1 = Time Limit
Collision	1	0 = No collisions detected between objects on screen 1 = Collisions detected Purpose is to allow continuous game play (for demonstration or examination) without losing any ships.
Attr Sound	1	0 = No sound in attract mode 1 = Sound
Hardness	3	Higher # = higher difficulty 99 = Special attract feature
Two Cube	1	0 = 3 level Cube only 1 = 2 or 3 level Cube available
Max Bonus	5	Sets # of Bonuses awardable per game (0-5).
Nmbr Cor	5	Sets # of corridors traversed (1-54) before bonus points awarded (5000 p)
Disk	1	0 = Game thinks no disk player attached 1 = Game thinks disk player is attached 2 = Game uses alternate (identical) video track

Resets to "0" if disk player goes bad →

Use CUBE button to select parameter. Use TRACKBALL to change setting.

NOTE: If disk player is removed or turned off the game will sense that and generate substitute background video, after a two minute "search" for the disk.

BONUS SETTINGS

This section of the TEST MODE allows you to set the scores at which the consecutive bonuses are awarded. The number of consecutive bonuses awardable is set by the "MAX BONUS" setting under "PARAMETERS".

All bonus score settings are settable in increments of 1000 only.

Use CUBE button to select which bonus score is to be changed. Use TRACKBALL to change score setting.

FACTORY SETTINGS ARE:

1st Bonus	25,000
2nd Bonus	50,000
3rd Bonus	75,000
4th Bonus	100,000
5th Bonus	125,000

COIN AUDIT TOTALS
(TIMED)

These are readings of the total coins and credits logged on the game since last reset.

Also included are the number of bonus credits awarded (if any) and the ratio of bonuses to credits awarded.

Use TEST button to reset readings.

COIN AUDIT TOTALS
(PERMANENT)

Same as "TIMED" COIN AUDIT TOTALS, except these figures are only reset by battery failure, or battery failure simulation test.

GAME AUDIT TOTALS
(TIMED)

These are readings of important game play features, such as total time played, average time per game, bonus time played, ratio of time played versus time powered up, total number of bonuses, and total number of tilts.

Use TEST button to reset readings.

GAME AUDIT TOTALS
(PERMANENT)

Same as "TIMED" GAME AUDIT TOTALS, except these figures are only reset by battery failure, or battery failure simulation test.

BONUS TOTALS
(TIMED)

These are the totals for each number of bonus ships awarded. That is, how many times players have reached 3 bonus ships, or 4 bonus ships, etc.

Use TEST button to reset readings.

BONUS TOTALS
(PERMANENT)

Same as "TIMED" BONUS TOTALS, except these figures are only reset by battery failure or battery failure simulation test.

CUBIC HISTORY

These are the ten highest recorded scores and corresponding initials since last reset, battery failure, or battery failure simulation.

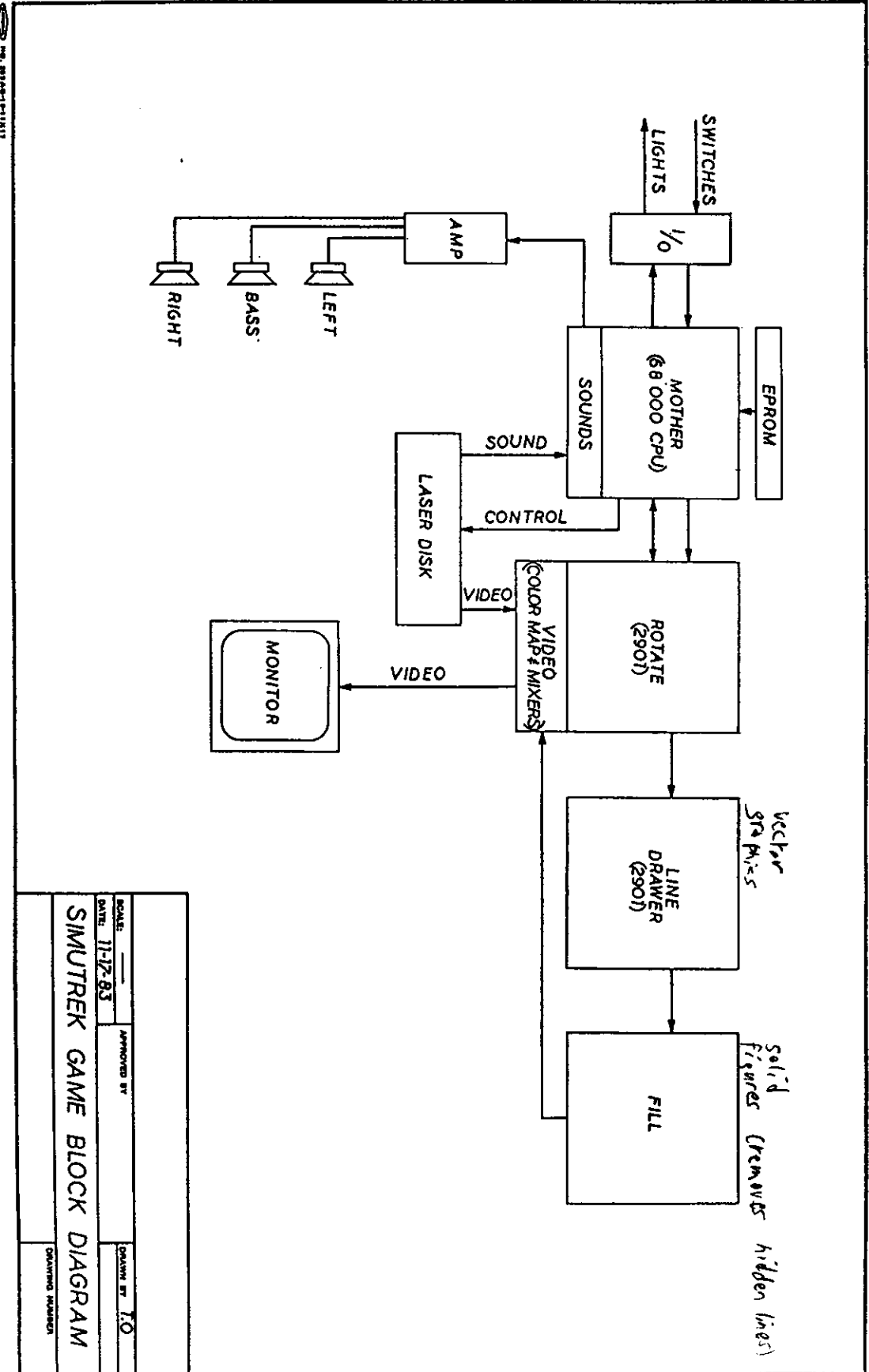

DATE: 11-12-83		APPROVED BY:	
DRAWN BY: JO		DRAWING NUMBER:	
SIMUTREK GAME BLOCK DIAGRAM			

NO. 883861-01/1113

FUNCTIONS OF PC BOARDS

MOTHER/SOUNDS Printed Circuit Board

68000 Microprocessor
All sound processing circuitry
I/O circuitry (e.g. buttons, lamps, trakball) (these functions shared w/"I/O bd.)
Laser Disk control interface
Laser Disk sound input (buffer, summer, etc.)
Battery backed RAM

ROTATE VIDEO Printed Circuit Board

Rotate Processor (2901) (1st processor in the real-time graphics chain)
All Video Circuitry:
1. Laser Disk NTSC Decoder
2. Laser Disk "Gen-Lock" Sync Generator
3. Real-time graphics color map (LUT)
4. RGB DAC's (Digital to Analog Converters and Video Mixers)

NOTE: If NO real-time graphics, this board is likely problem

LINE DRAWER Printed Circuit Board

(2nd Board in the real-time graphics chain)
Vector Generator
Run Length Encoding (i.e. Start & Stop Point Derivation)

FILL Printed Circuit Board

Does Run Length conversion into actual "painting of the pixels"
Depth Buffer (essentially hidden surface removal)
Consists of four identical subcircuits which alternate every horizontal line (if one is bad, every 4th line will appear bad)

NOTE: Video, in digital form, leaves this board to pass through the color map located on the ROTATE/VIDEO board, then to the DAC's and Video Mixers also located on the ROTATE/VIDEO board.

EPRM Printed Circuit Board

Game Program
Diagnostics Program

I/O Printed Circuit Board

Switch Filters (for FCC requirements)
Trakball Interface (Schmitt Trigger Comparators)
Current Drivers (for lamps in switches, coin counters)

AUDIO POWER AMP Printed Circuit Board

Left channel audio amp
Right channel audio amp
Bass (or center) channel audio amp
Center channel low pass filter

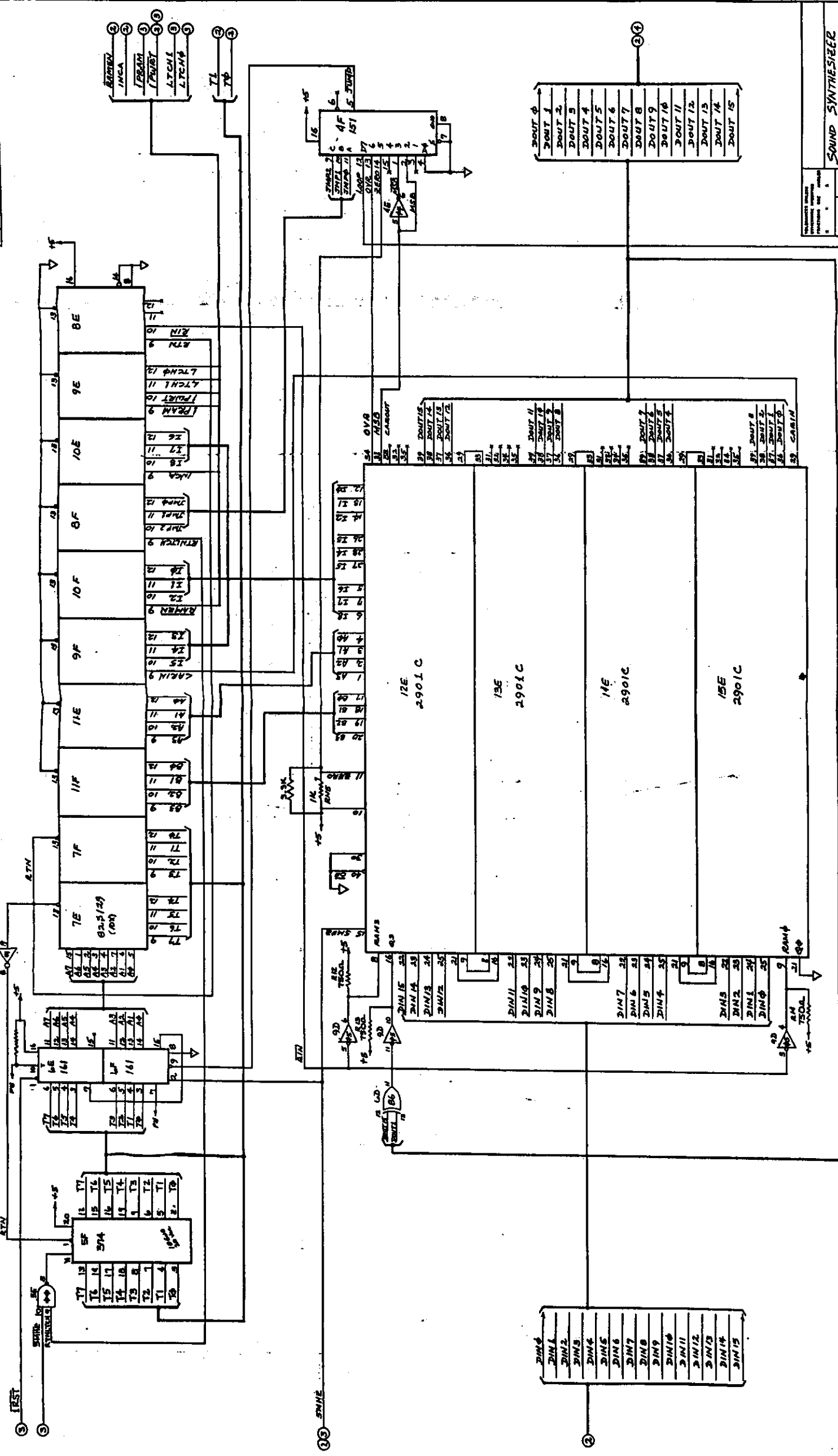

SOUND SYNTHESIZER
 ALU AND MICROCODE
 SCALE: 100%
 SHEET: 1 OF 1
 DATE: 1/18/83
 DRAWN BY: [Signature]
 CHECKED BY: [Signature]

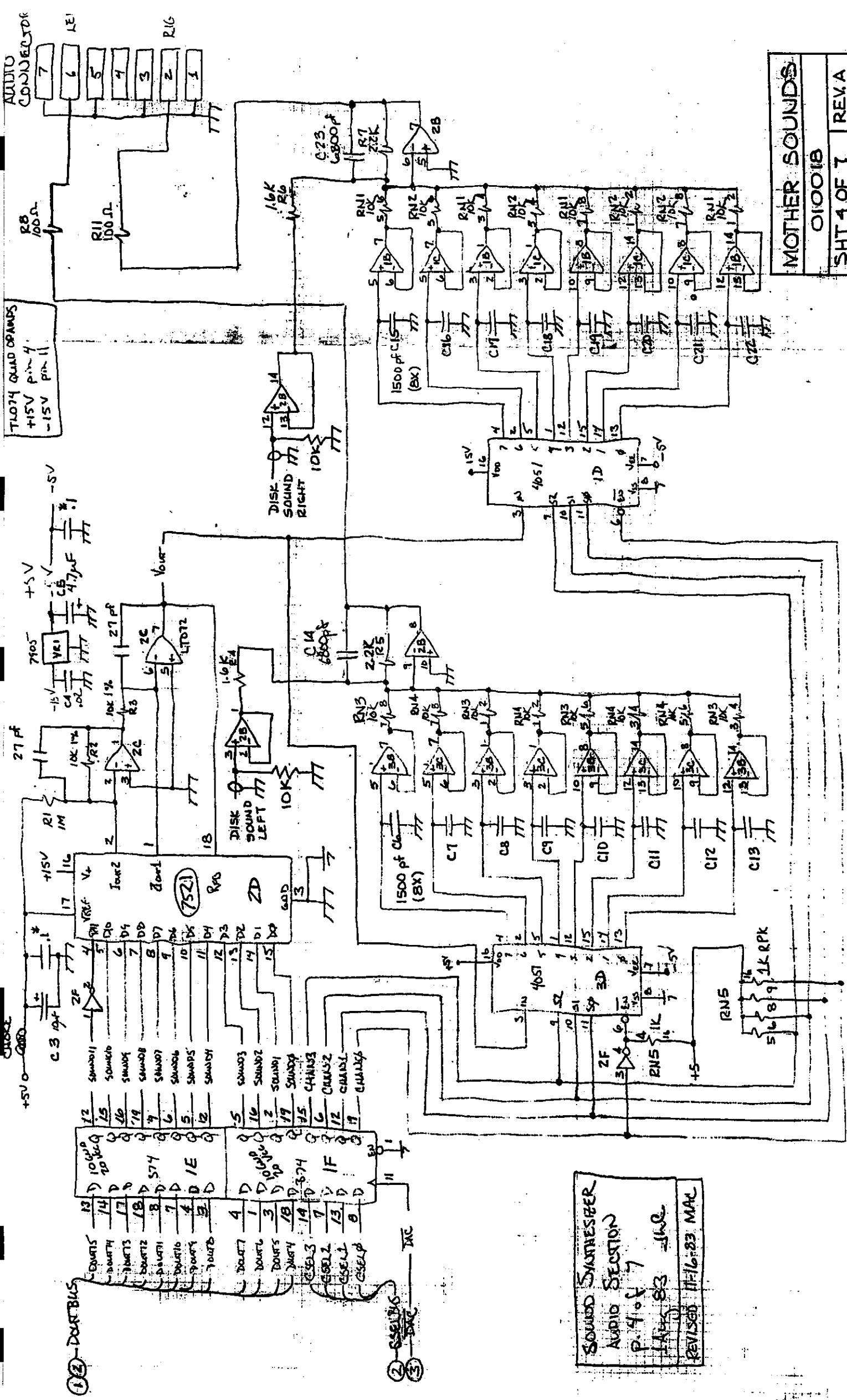

MOTHER SOUNDS
O1001B
SHT 4 OF 7 REV A

SOUND SYNTHESIZER
AUDIO SECTION
P. 4 OF 7
JAN 83 JWC
REVISED 11-16-83 MAC

12 - DATA BUS

2 - SERIAL BUS
3 - SYNC

13	10	11	12	13	14	15	16	17	18	19	20	21	22	23	24	25	26	27	28	29	30	31	32	33	34	35	36	37	38	39	40	41	42	43	44	45	46	47	48	49	50	51	52	53	54	55	56	57	58	59	60	61	62	63	64	65	66	67	68	69	70	71	72	73	74	75	76	77	78	79	80	81	82	83	84	85	86	87	88	89	90	91	92	93	94	95	96	97	98	99	100
13	14	15	16	17	18	19	20	21	22	23	24	25	26	27	28	29	30	31	32	33	34	35	36	37	38	39	40	41	42	43	44	45	46	47	48	49	50	51	52	53	54	55	56	57	58	59	60	61	62	63	64	65	66	67	68	69	70	71	72	73	74	75	76	77	78	79	80	81	82	83	84	85	86	87	88	89	90	91	92	93	94	95	96	97	98	99	100				
13	14	15	16	17	18	19	20	21	22	23	24	25	26	27	28	29	30	31	32	33	34	35	36	37	38	39	40	41	42	43	44	45	46	47	48	49	50	51	52	53	54	55	56	57	58	59	60	61	62	63	64	65	66	67	68	69	70	71	72	73	74	75	76	77	78	79	80	81	82	83	84	85	86	87	88	89	90	91	92	93	94	95	96	97	98	99	100				
13	14	15	16	17	18	19	20	21	22	23	24	25	26	27	28	29	30	31	32	33	34	35	36	37	38	39	40	41	42	43	44	45	46	47	48	49	50	51	52	53	54	55	56	57	58	59	60	61	62	63	64	65	66	67	68	69	70	71	72	73	74	75	76	77	78	79	80	81	82	83	84	85	86	87	88	89	90	91	92	93	94	95	96	97	98	99	100				

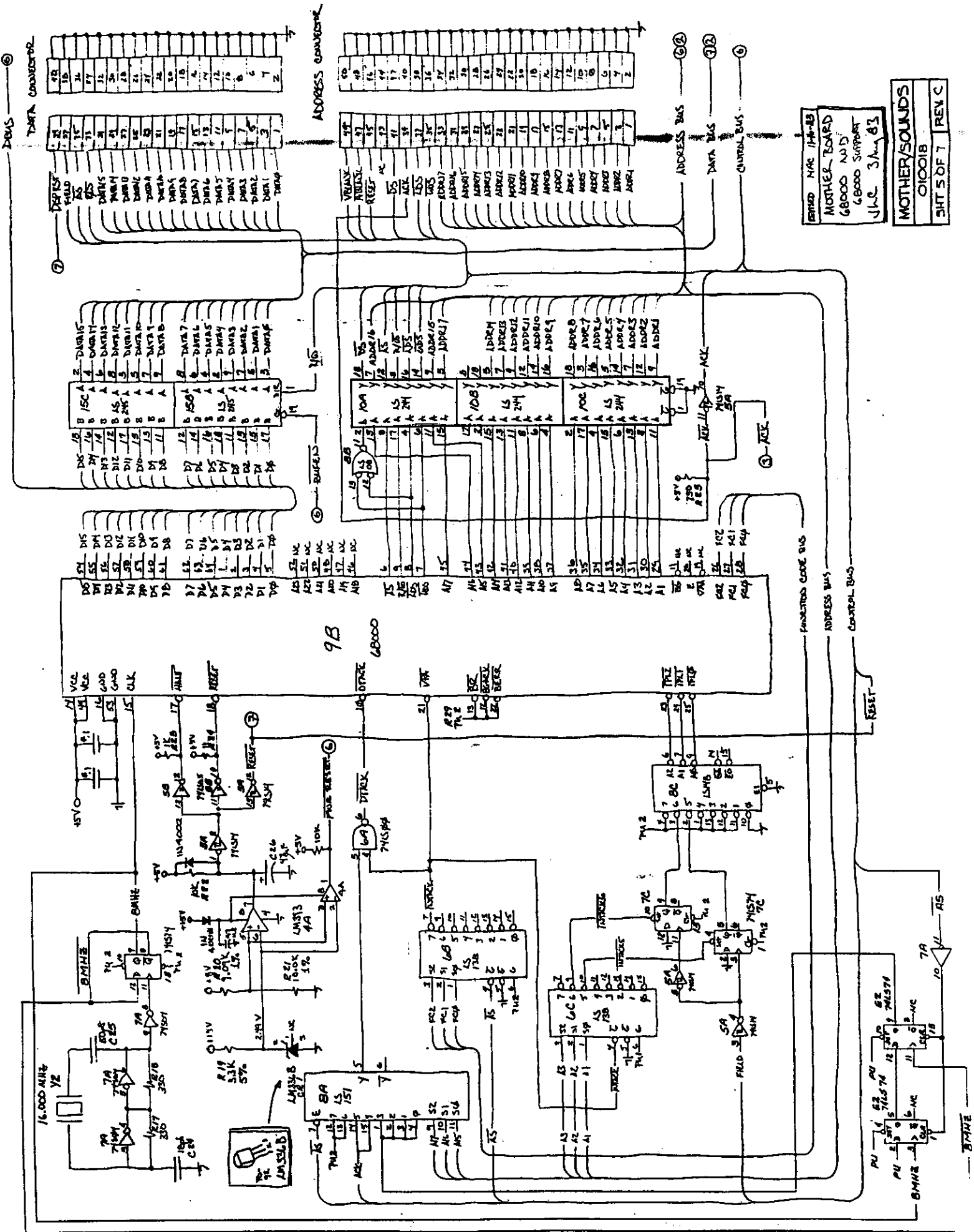

PART NO. 148-48
 MOTHER BOARD
 68000 N/D
 68000 SUPPORT
 JHC 3 May 83
 MOTHER/SOUNDS
 010018
 SHT 5 OF 7 REV C

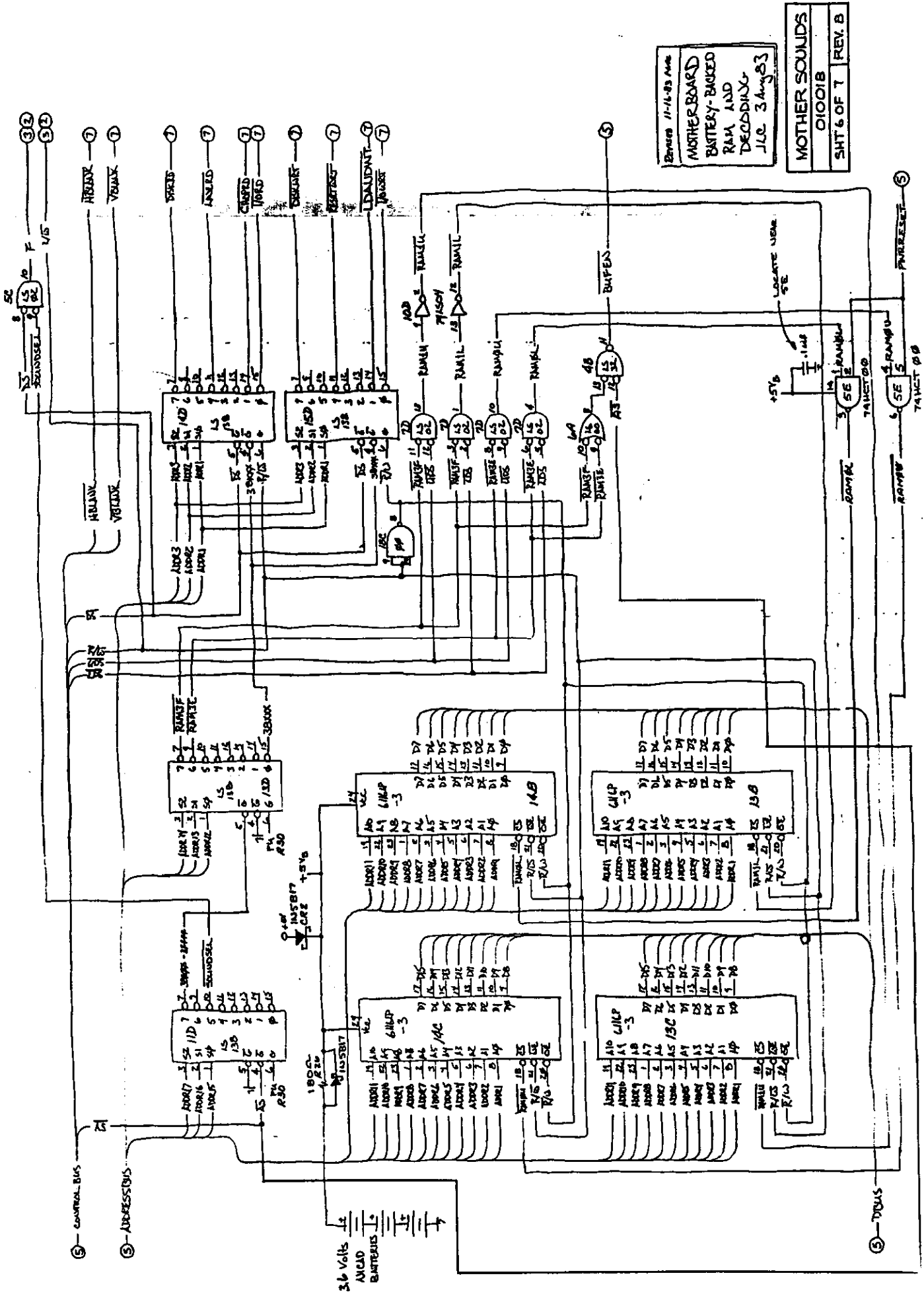

REVISED 11-16-83
MOTHER SOUNDS
 BATTERY-BACKED
 RAM AND
 DECODING
 JLC 3 Aug 83

MOTHER SOUNDS
 01001B
 SHT 6 OF 7 REV. B

RNI, 2, 3, 4 = 8PIN, 5V, 4 @ 10K Ω
 RNS = 10PIN, 5V, 9 @ 1K Ω
 RNB, 7 = 10PIN, 5V, 9 @ 3.3K Ω

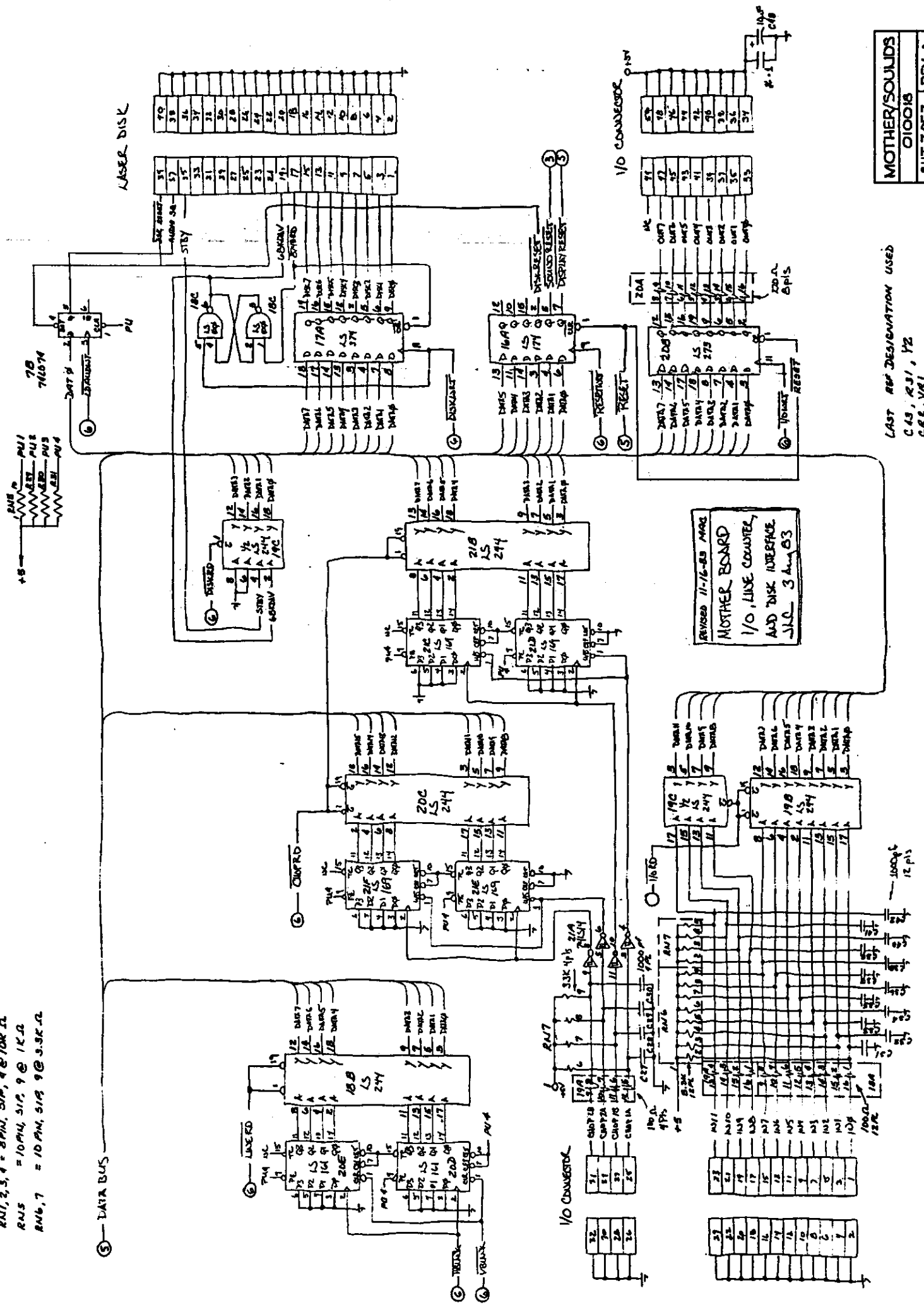

REVISED 11-16-83 MROC
MOTHER BOARD
 I/O LINE CONTROLLER
 AND DISK INTERFACE
 JLC 3 Aug 83

MOTHER/SOULDS
 010018
 SMT70FT REV A

LAST REF DESIGNATION USED
 CAS, R31, Y2
 CR2, VRI
 L1, RNT

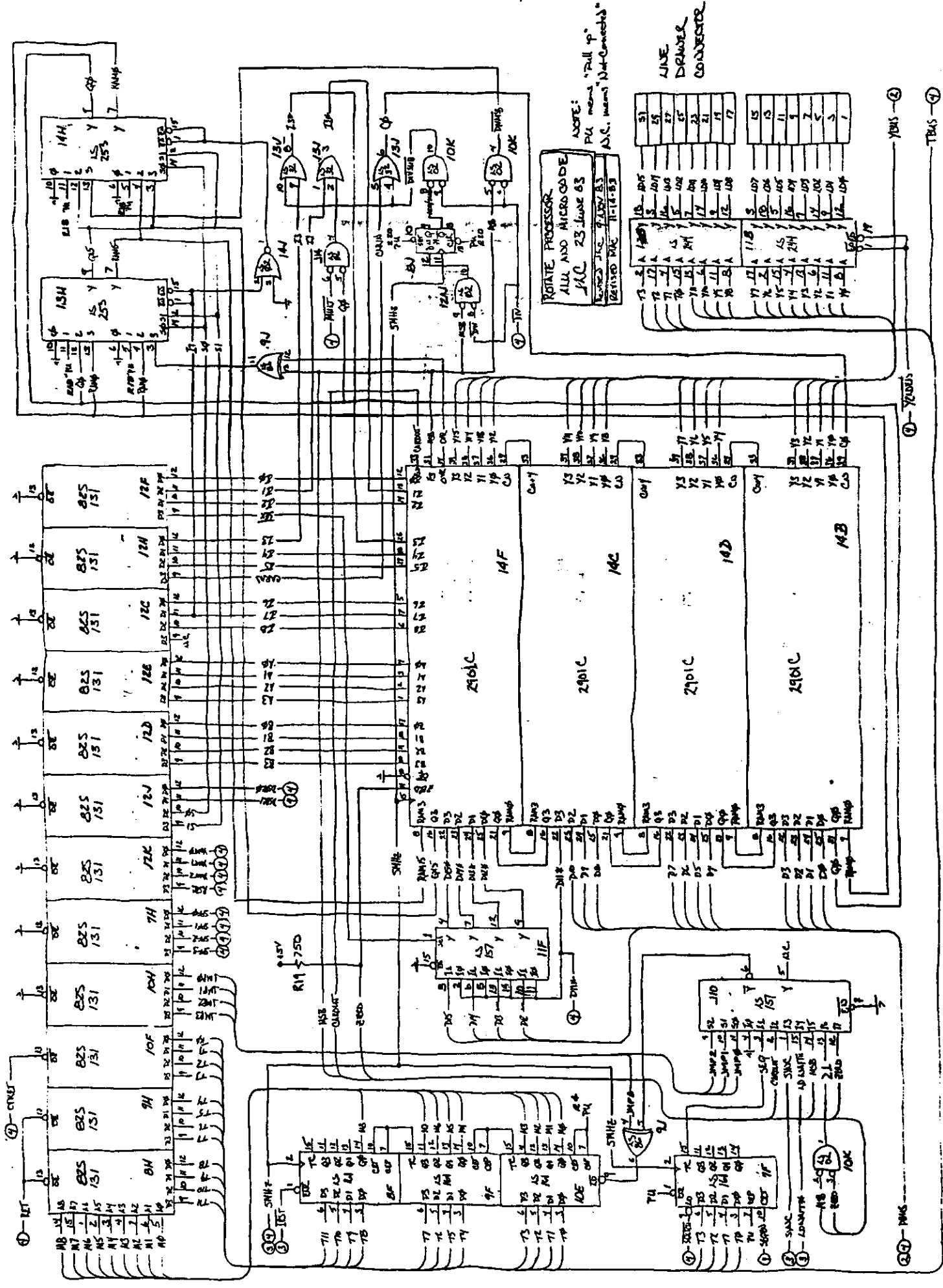

NOTE:
 PU mems "Full p"
 A.S.C. mems "Not Connected"

LINE
 DRIVER
 CONVERTOR

ROTATE PROCESSOR
 ALL AND MICROCODE
 14C 23 June 63
 REVISED JIC 74181 83
 REVISED MAC 11-14-63

73	A	100	105	105	51
74	A	100	105	105	51
75	A	100	105	105	51
76	A	100	105	105	51
77	A	100	105	105	51
78	A	100	105	105	51
79	A	100	105	105	51
80	A	100	105	105	51
81	A	100	105	105	51
82	A	100	105	105	51
83	A	100	105	105	51
84	A	100	105	105	51
85	A	100	105	105	51
86	A	100	105	105	51
87	A	100	105	105	51
88	A	100	105	105	51
89	A	100	105	105	51
90	A	100	105	105	51
91	A	100	105	105	51
92	A	100	105	105	51
93	A	100	105	105	51
94	A	100	105	105	51
95	A	100	105	105	51
96	A	100	105	105	51
97	A	100	105	105	51
98	A	100	105	105	51
99	A	100	105	105	51
100	A	100	105	105	51

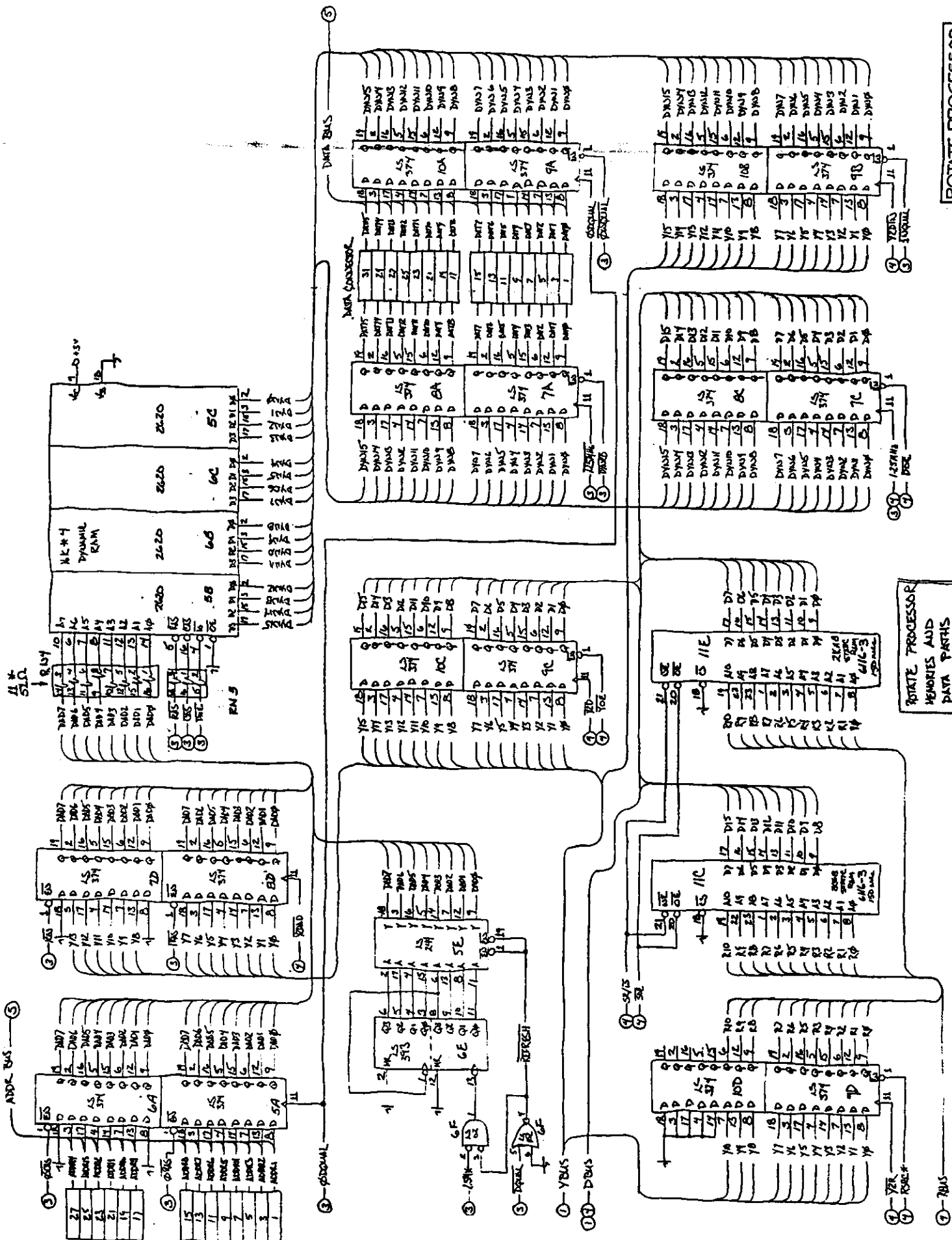

ROTATE PROCESSOR
010030
SHT 2 OF 7 REV. A

ROTATE PROCESSOR
MEMORIES AND
DATA PARTS
JLC 22 June 63
Revised JLC 9 (22) 63
Revised MC 11-11-63

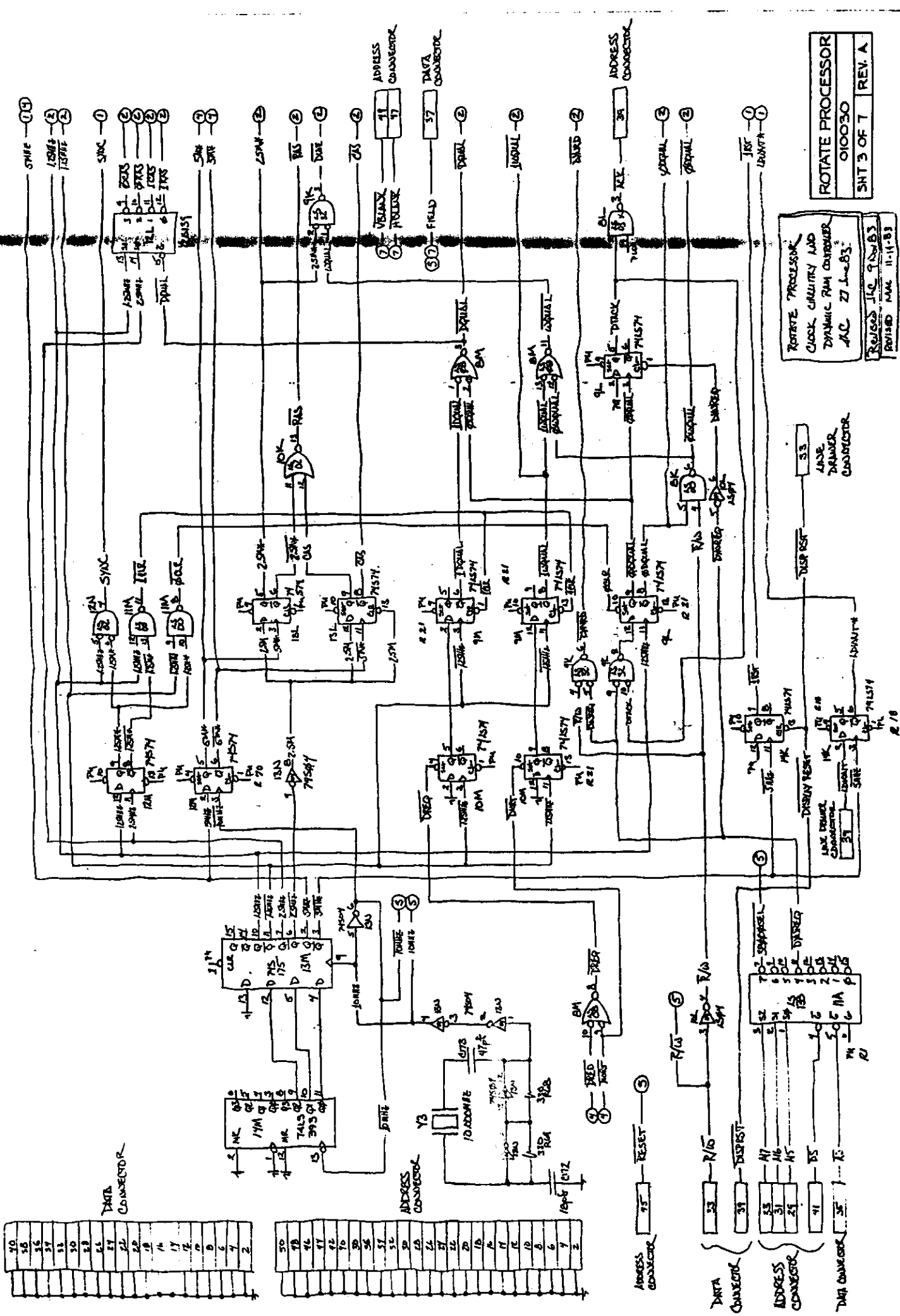

ROTARE PROCESSOR
 CHECK QUALITY AND
 DYNAMIC RAM OUTPUTS
 AC 27.1.83
 REVISED I/O 9.2.83
 REVISED PAL 11.11.83

ROTARE PROCESSOR
010030
SMT 3 OF 7 REV. A

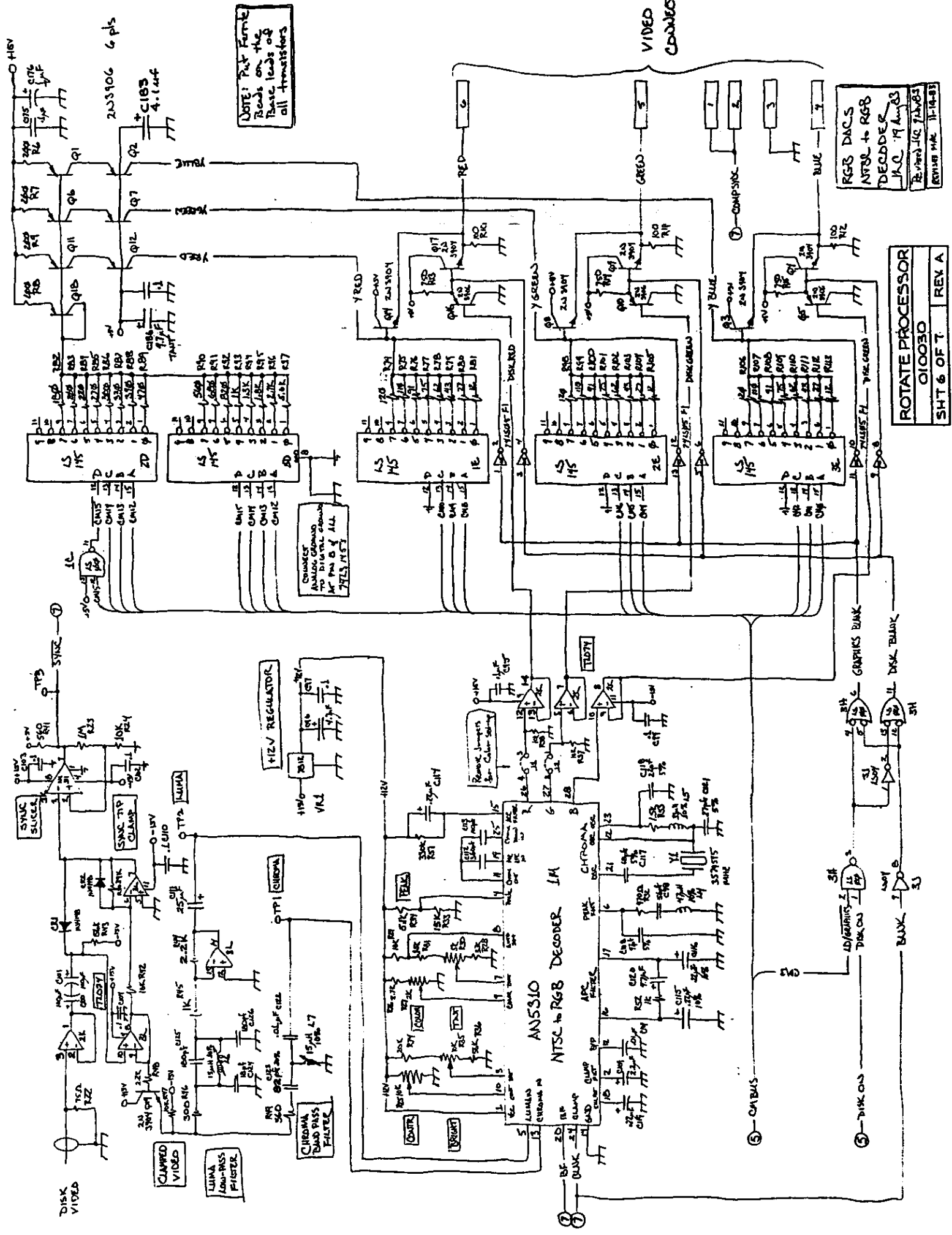

NOTE: Put Ferrite Beads on the Base leads of all transistors

RGB DACS
NTSC to RGB
DECODER
JRC 74180
Rev. 1/14/83
REVISED FROM 11-14-83

ROTATE PROCESSOR
C10030
SHT 6 OF T. REV. A

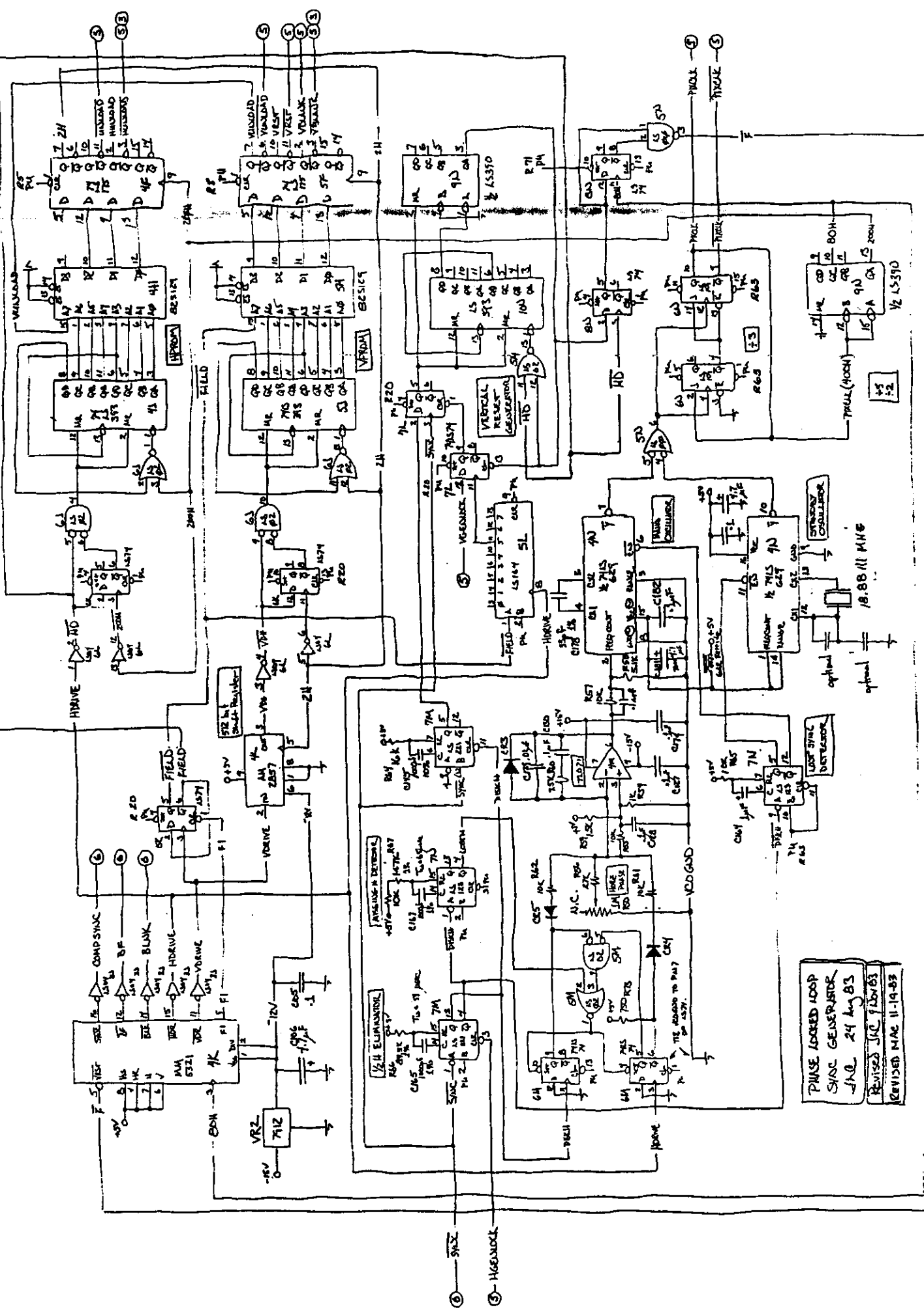

ROTATOR PROCESSOR
O10030
SHT 7 OF 7 REV. B

PULSE ADDRESS LOOP
SYNC GENERATOR
JAC 24 Aug 83
Revised JAC 9/28/83
Revised MAC 11-19-83

② SYNC
③ HGENLOCK

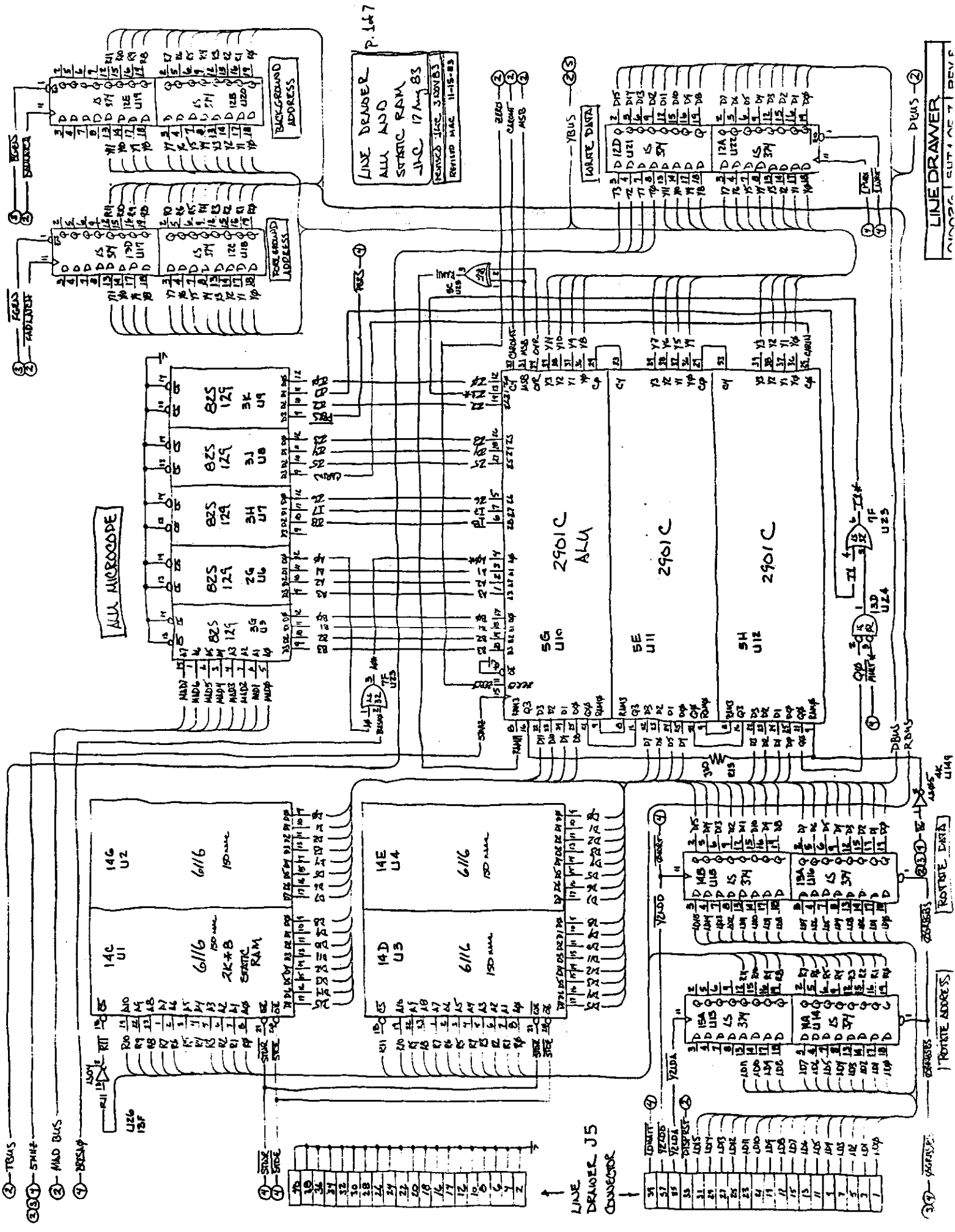

- ③ - YBUS
- ③④ - SMHZ
- ③ - MID BUS
- ⑦ - BRESAP

- ④ - STKZ
- ④ - STKZ

LINE DRAWER J5 CONNECTOR

- ③⑦ - BRESAP
- ③⑧ - PORTITE ADDRESS
- ③⑨ - PORTITE DATA
- ④ - LINE DRAWER

P. 147
 LINE DRAWER
 ALL ADD
 STATIC RAM
 JIC 17 May 83
 REVISED I/OE 320V83
 REVISED MAC 11-18-83

LINE DRAWER
 JIC 17 May 83
 REVISED I/OE 320V83
 REVISED MAC 11-18-83

ALU MICROCODE

2901C
 ALU

2901C

2901C

14C U1

14G U2

14D U3

14E U4

14C U1

14G U2

14D U3

14E U4

14C U1

14G U2

14D U3

14E U4

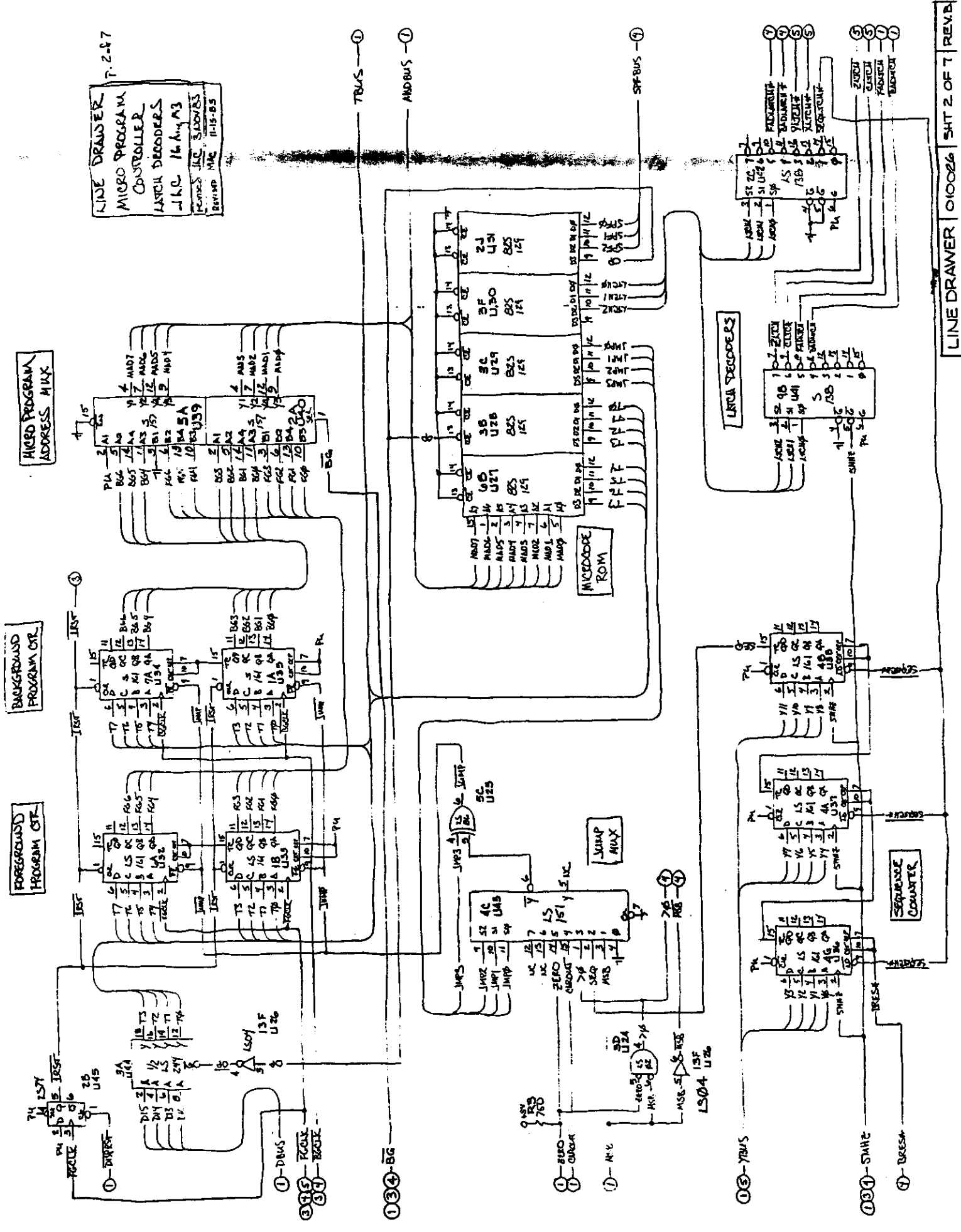

LINE DRAWER 7-247
 MICRO PROGRAM
 CONTROLLER
 LATCH DECODERS
 -LHC 16-A-M3
 James J.R. Sloves
 Revised MAR 11-15-85

MICRO PROGRAM
 ADDRESS MIXER

BACKGROUND
 PROGRAM CTR.

BACKGROUND
 PROGRAM CTR.

LATCH DECODERS

SEQUENCE
 COUNTER

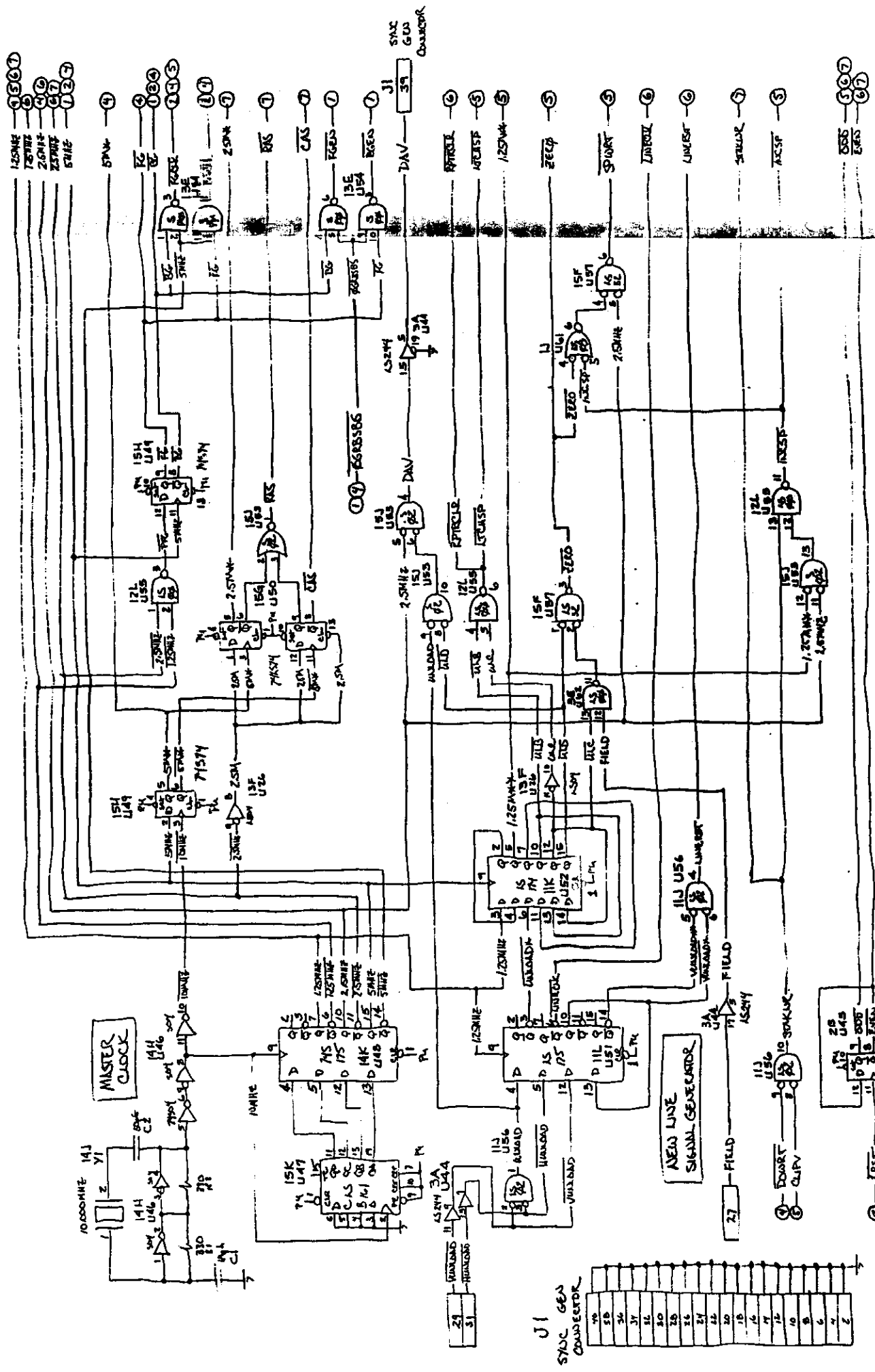

LINE DRAWER
DRWG. NO. 010026
REV. B
SHT 3 OF 7

LINE DRAWER
 CLOCKS AND
 DYNAMIC RAM
 CONTROLLER
 JAC 1/14/83
 DESIGNED BY: JAC
 CHECKED BY: JAC
 APPROVED BY: JAC

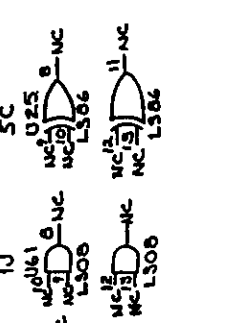

SPARES

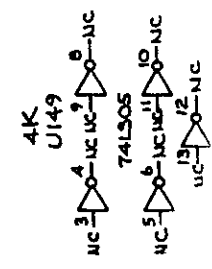

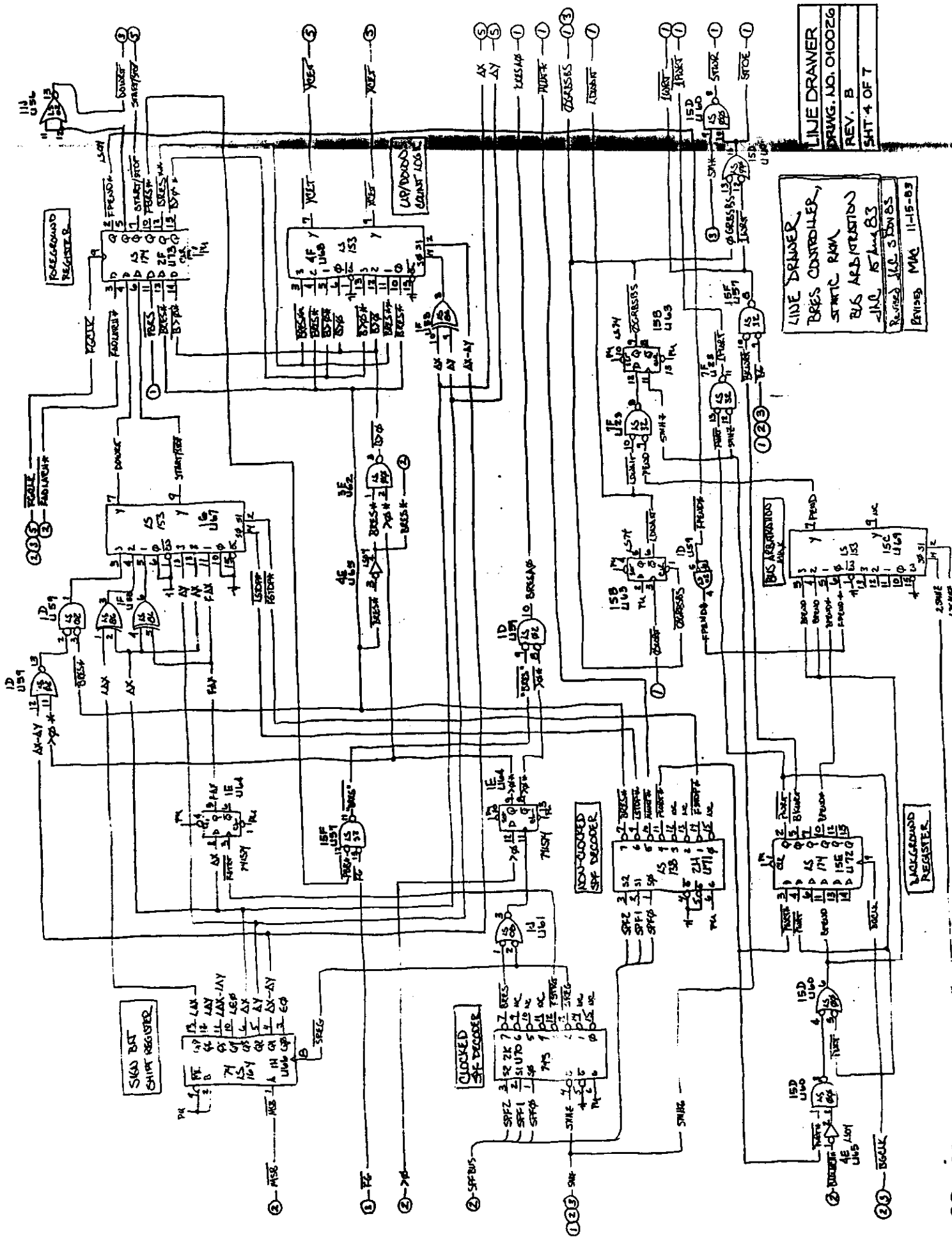

LINE DRAWER
 BRG. NO. 010026
 REV. B
 SHT. 4 OF 7

LINE DRAWER
 BRES CONTROLLER,
 STATIC RAM
 BUS ADDRESS RAM
 JNL 15 Aug 83
 Revised J.R. Stevens
 REVISED MJC 11-15-83

LINE DRAWER
 4 1/2 V COUNTERS,
 STACK POINTER RAM
 JLC 12 Aug 83
 REVISED JLC 3 20VBS
 REVISED MAR 11-15-83

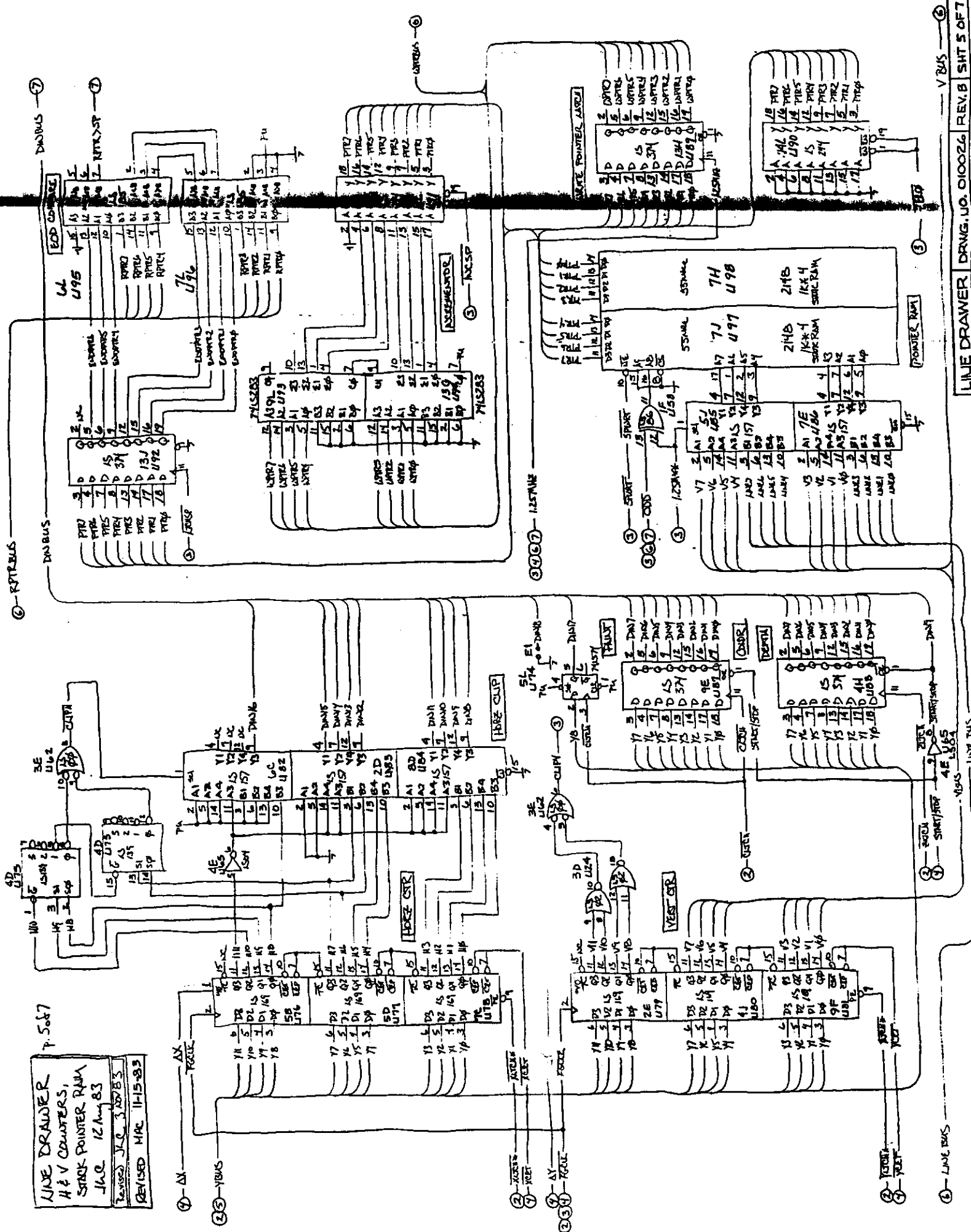

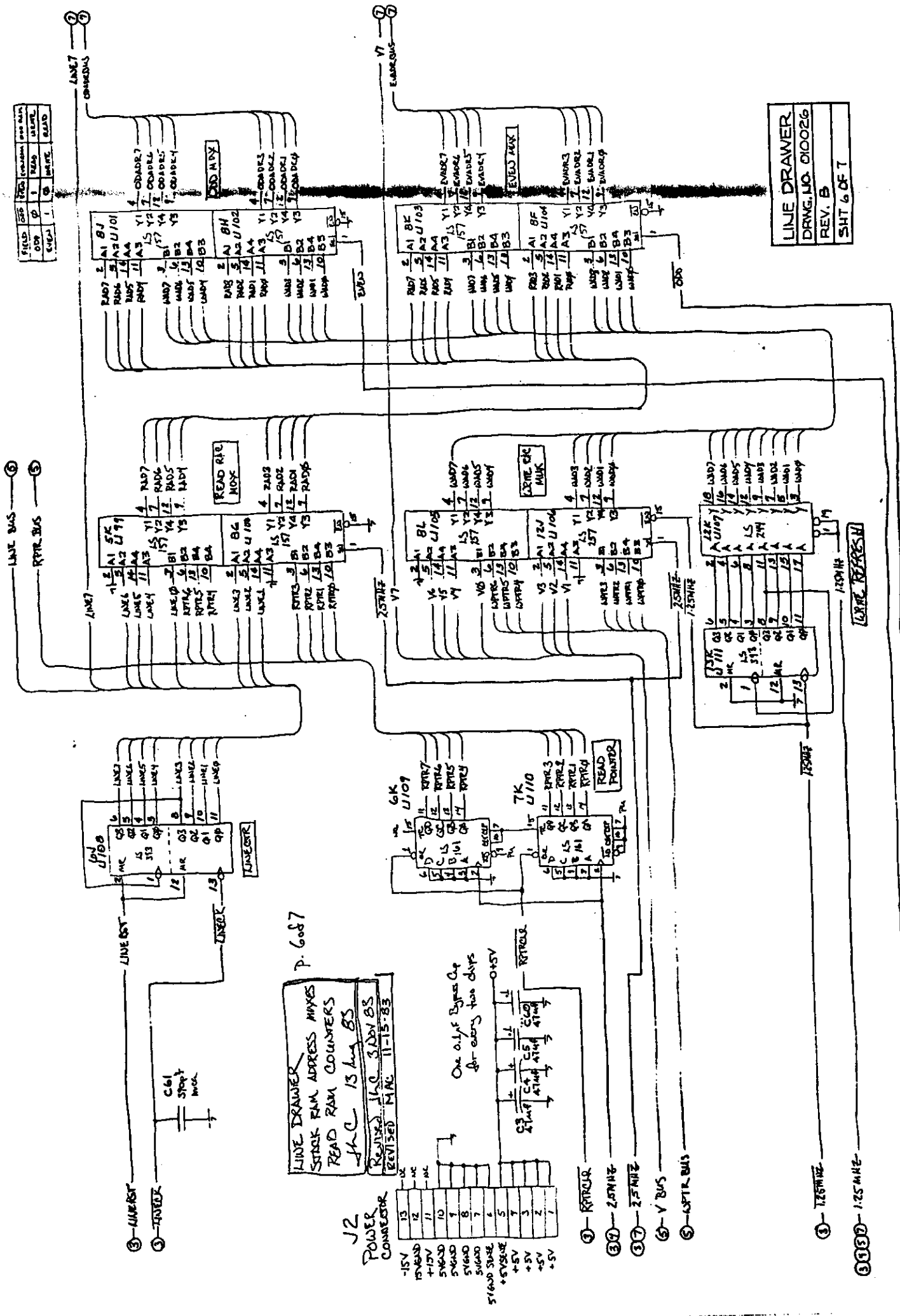

LINE DRAWER
 DRWG. NO. D10026
 REV. B
 SHT 6 OF 7

LINE DRAWER
 STRIKE RAM ADDRESS MIXES
 READ RAM COUNTERS
 JLC 13 Aug 85
 REVISED 11-15-83
 P. 6087

J2
 POWER CONNECTOR

13	NC
12	NC
11	NC
10	NC
9	NC
8	NC
7	NC
6	NC
5	NC
4	NC
3	NC
2	NC
1	NC

One only of Bypass Cap for every two chips

- ① - RTRBUS
- ② - Z5M1Z
- ③ - Z5M2Z
- ④ - V BUS
- ⑤ - OPTR BUS
- ⑥ - Z5M1Z
- ⑦ - Z5M2Z
- ⑧ - Z5M3Z
- ⑨ - Z5M4Z
- ⑩ - Z5M5Z
- ⑪ - Z5M6Z
- ⑫ - Z5M7Z
- ⑬ - Z5M8Z
- ⑭ - Z5M9Z
- ⑮ - Z5M10Z
- ⑯ - Z5M11Z
- ⑰ - Z5M12Z
- ⑱ - Z5M13Z
- ⑲ - Z5M14Z
- ⑳ - Z5M15Z
- ㉑ - Z5M16Z
- ㉒ - Z5M17Z
- ㉓ - Z5M18Z
- ㉔ - Z5M19Z
- ㉕ - Z5M20Z

④ - EVADR BUS
 ⑤ - COMPBUS
 ⑥ - EVADR BUS
 ⑦ - COMPBUS
 ⑧ - EVADR BUS
 ⑨ - COMPBUS

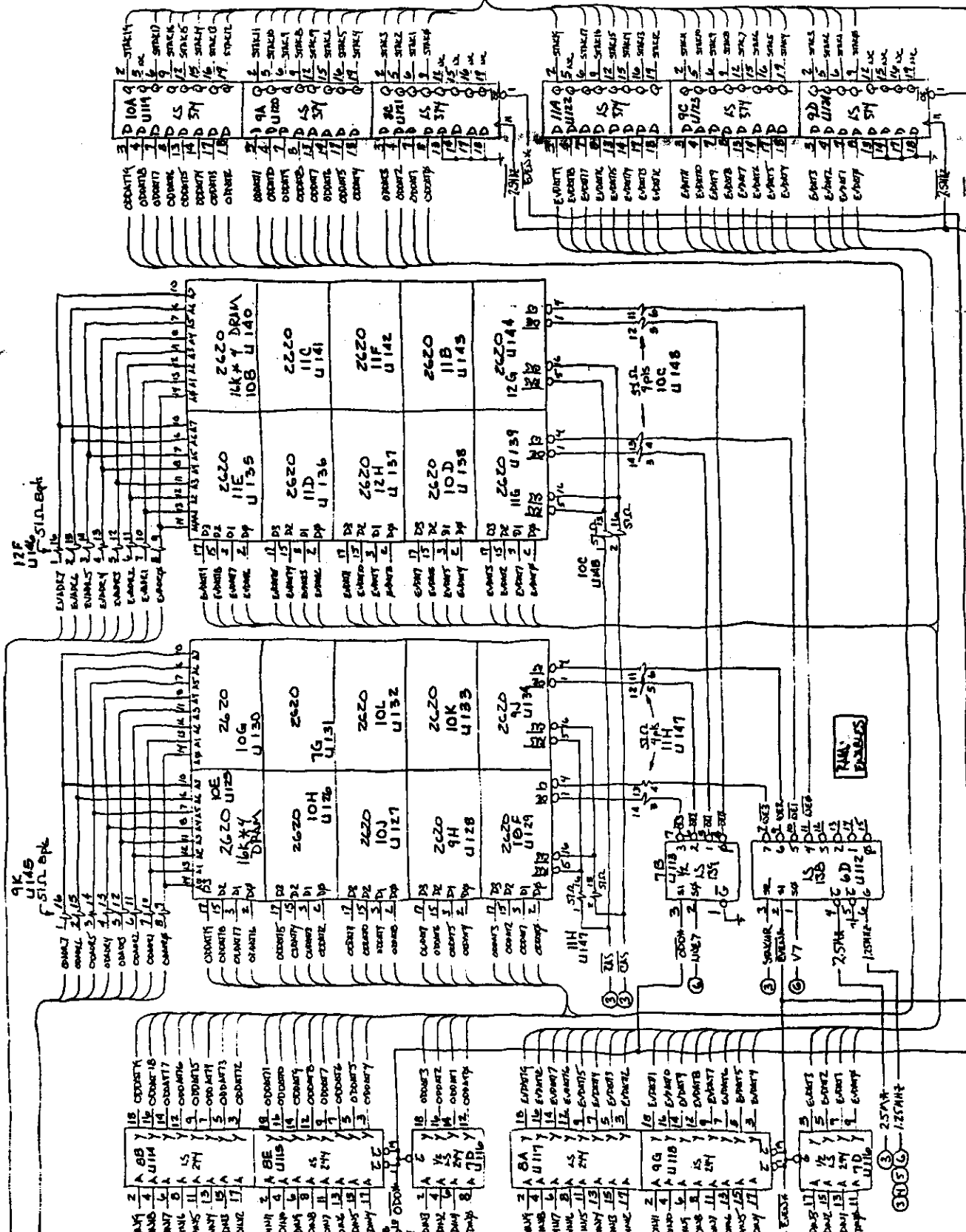

FIELD	REV	DATE	BY	CHKD	APP'D
01	1				
02	1				
03	1				

11H
 U147
 NC - JAW10-NC
 NC - JAW10-NC
 510

LINE DRAWER
 STACK RAM
 DATA PARTS
 JHC 11 Aug 83
 REVISED MAR 11-15-83

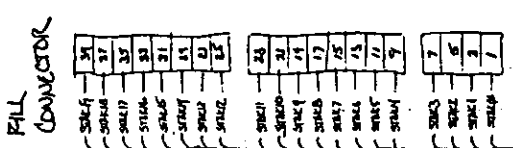
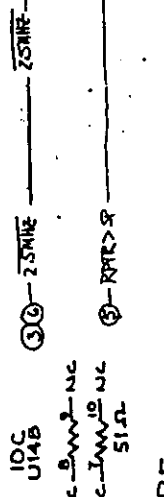
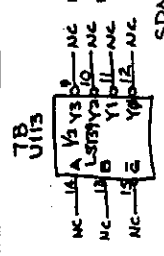

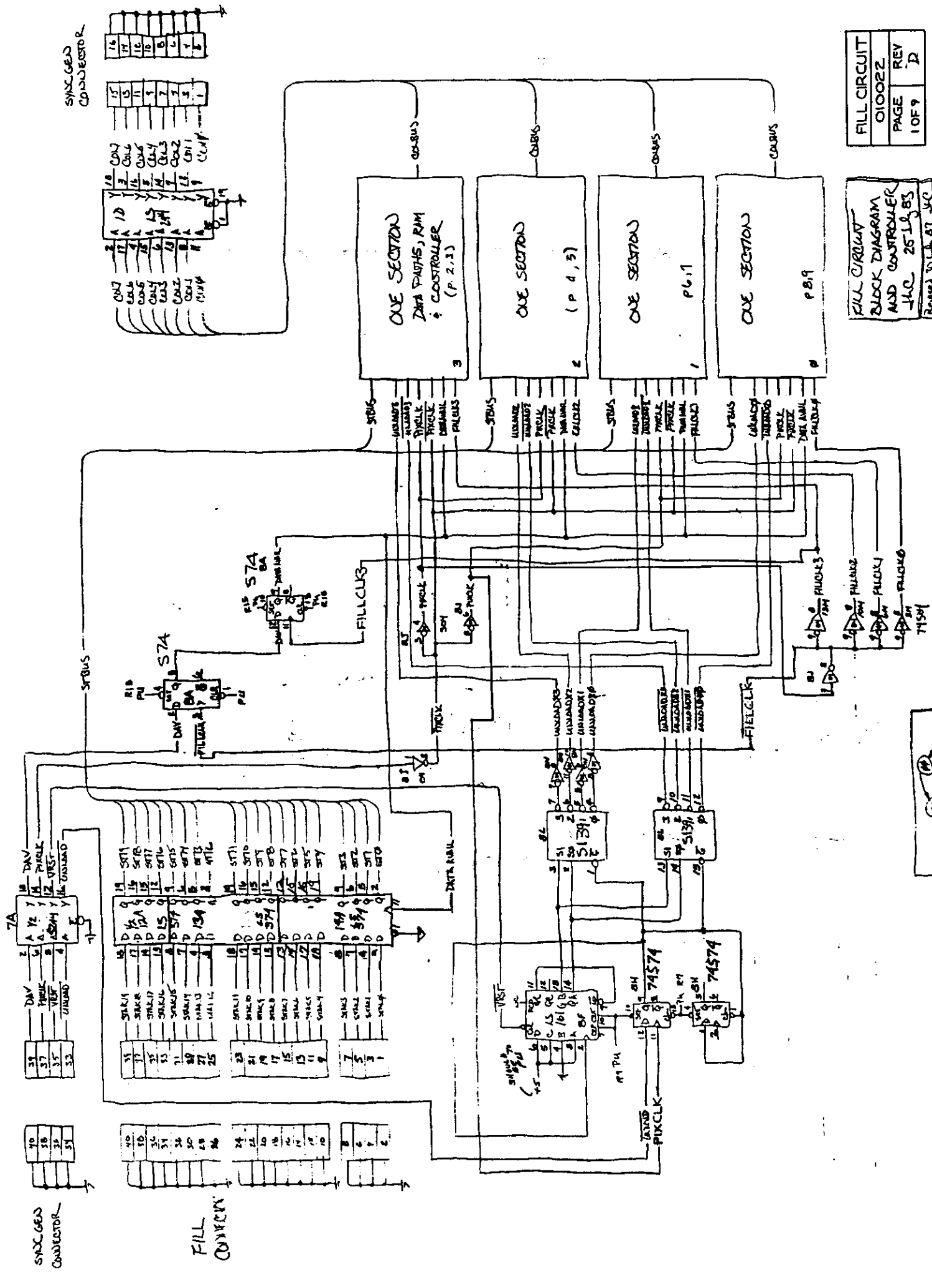

FILL CIRCUIT
 BLOCK DIAGRAM
 AND CONTROLLER
 JAC 25-10-83
 Revised 25-10-83 JAC
 Revised 25-10-83 JAC
 Revised 25-10-83 JAC
 Revised 25-10-83 JAC
 Revised 25-10-83 JAC

FILL CIRCUIT	01002Z
PAGE	10F9
REV	D

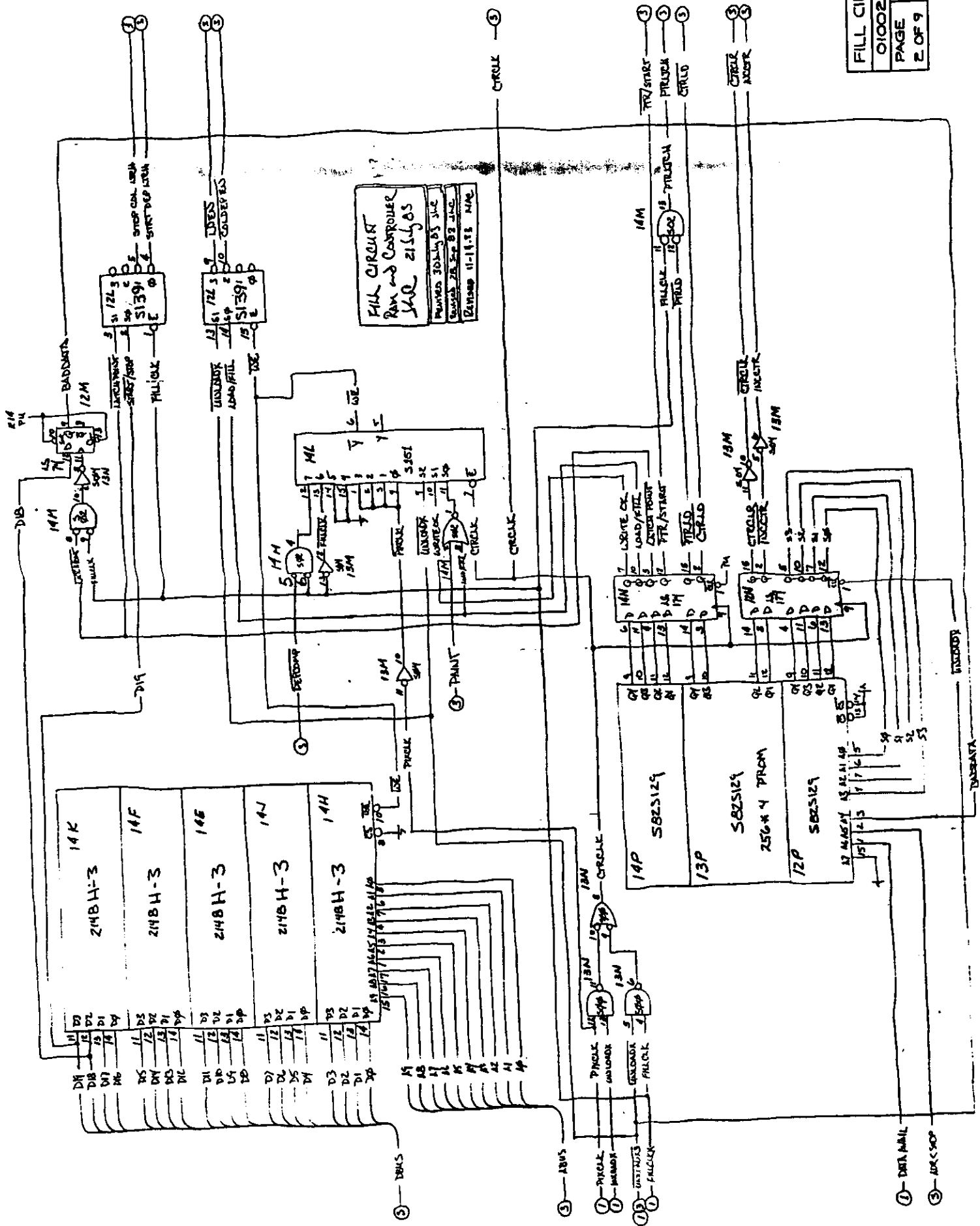

FILL CIRCUIT
 RAM and Controller
 YAO 21545 AS
 REVISED 30 JUN 68 SJC
 REVISED 28 SEP 68 JAC
 REVISED 11-19-78 NAC

FILL CIRCUIT	
O10022	
PAGE	REV.
2 OF 9	C

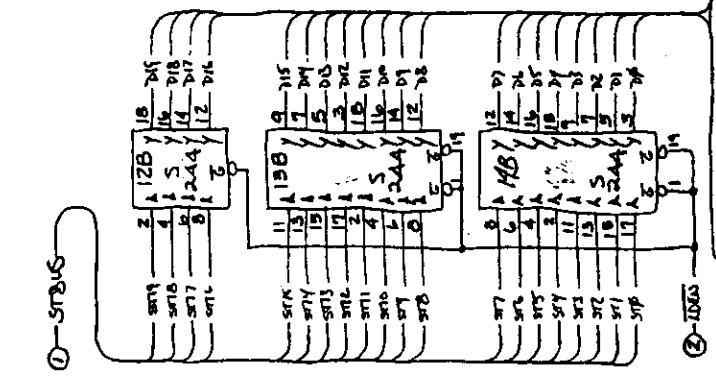
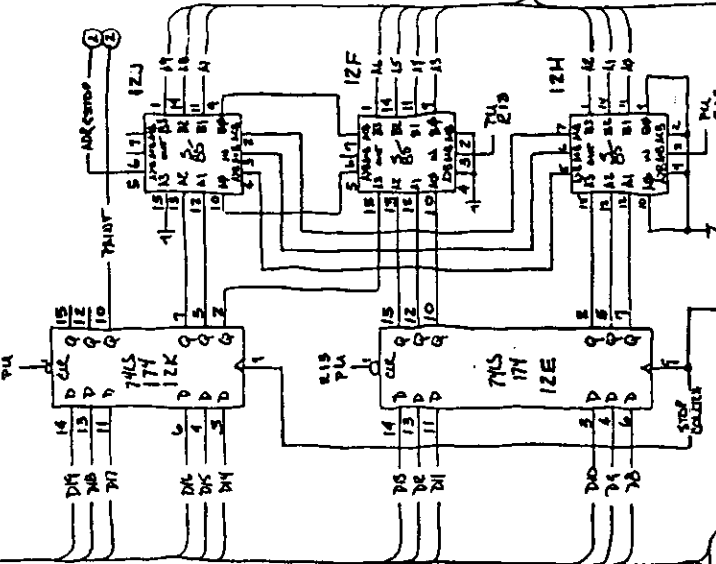
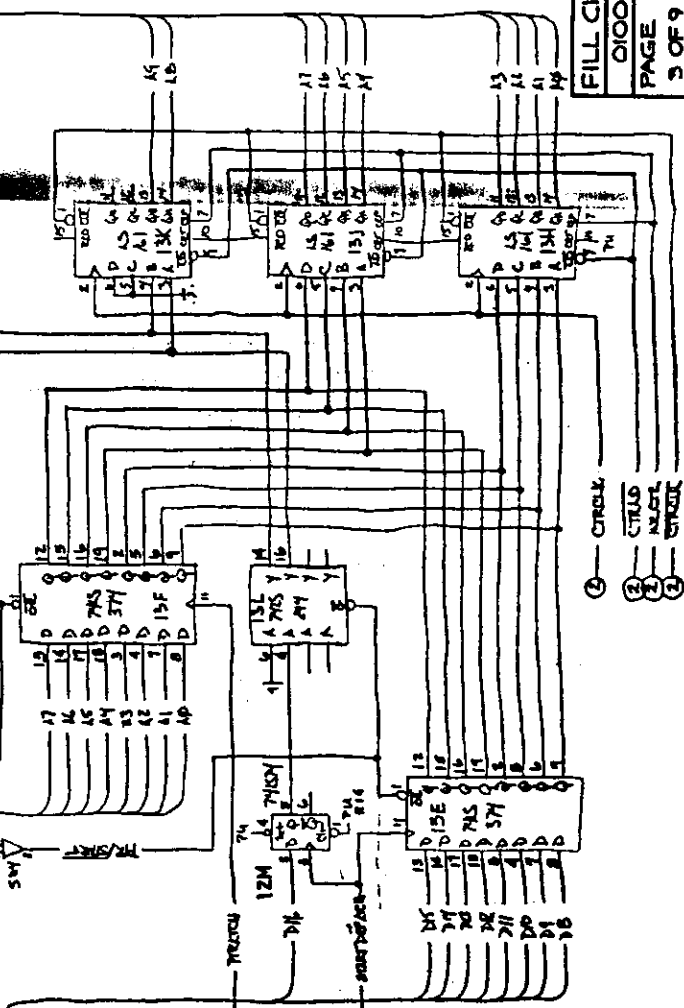
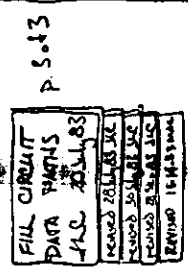
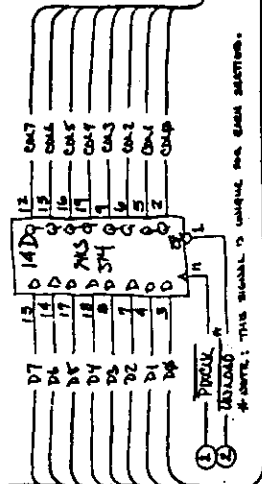
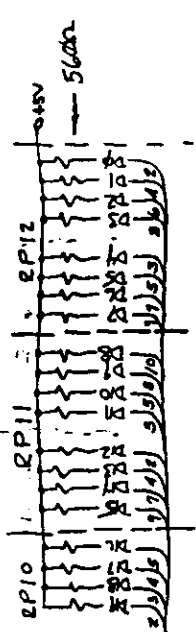
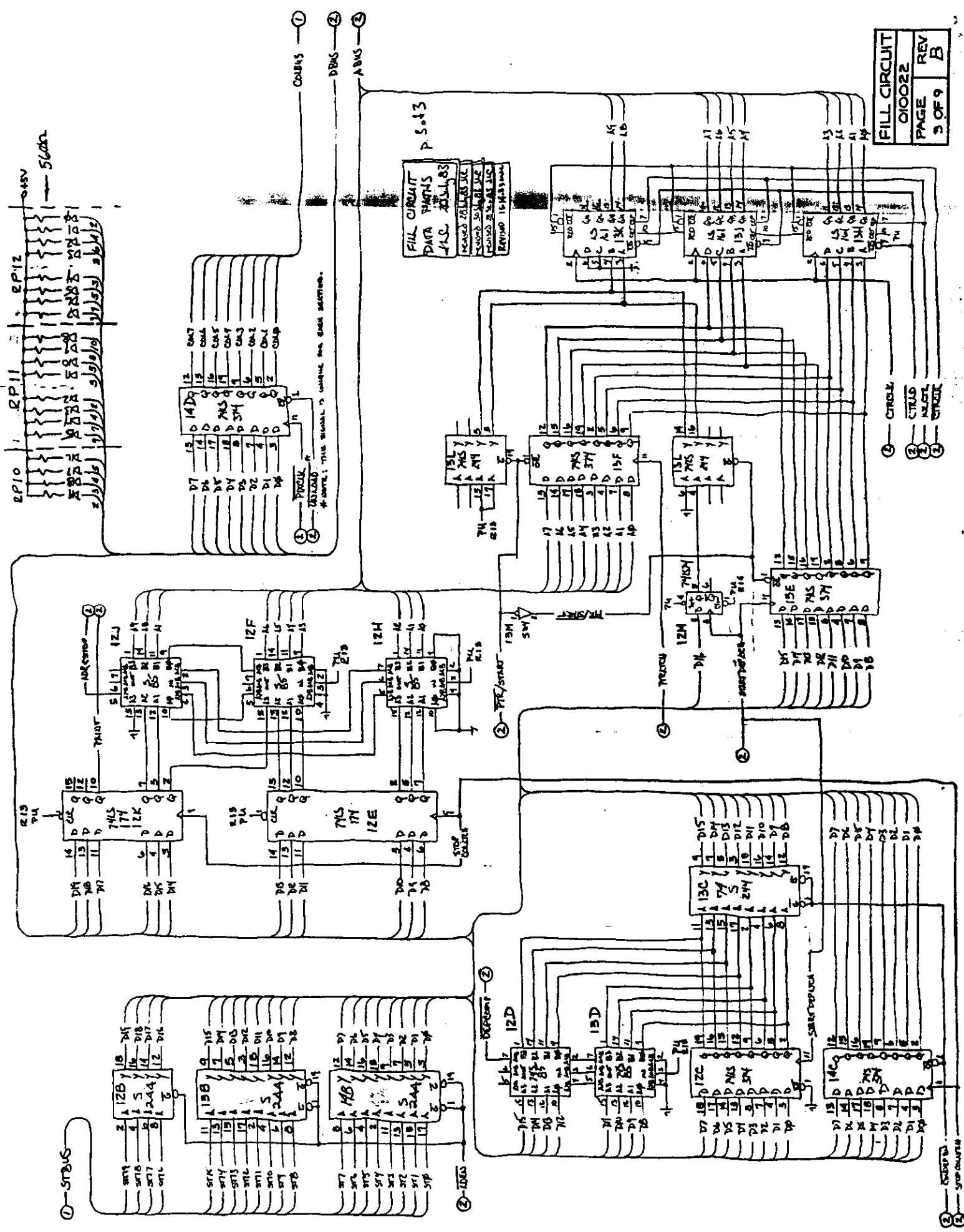

FILL CIRCUIT	
010022	
PAGE	REV
5 OF 9	B

- ① - COUNT
- ② - SRBUS
- ③ - DBUS
- ④ - ABUS

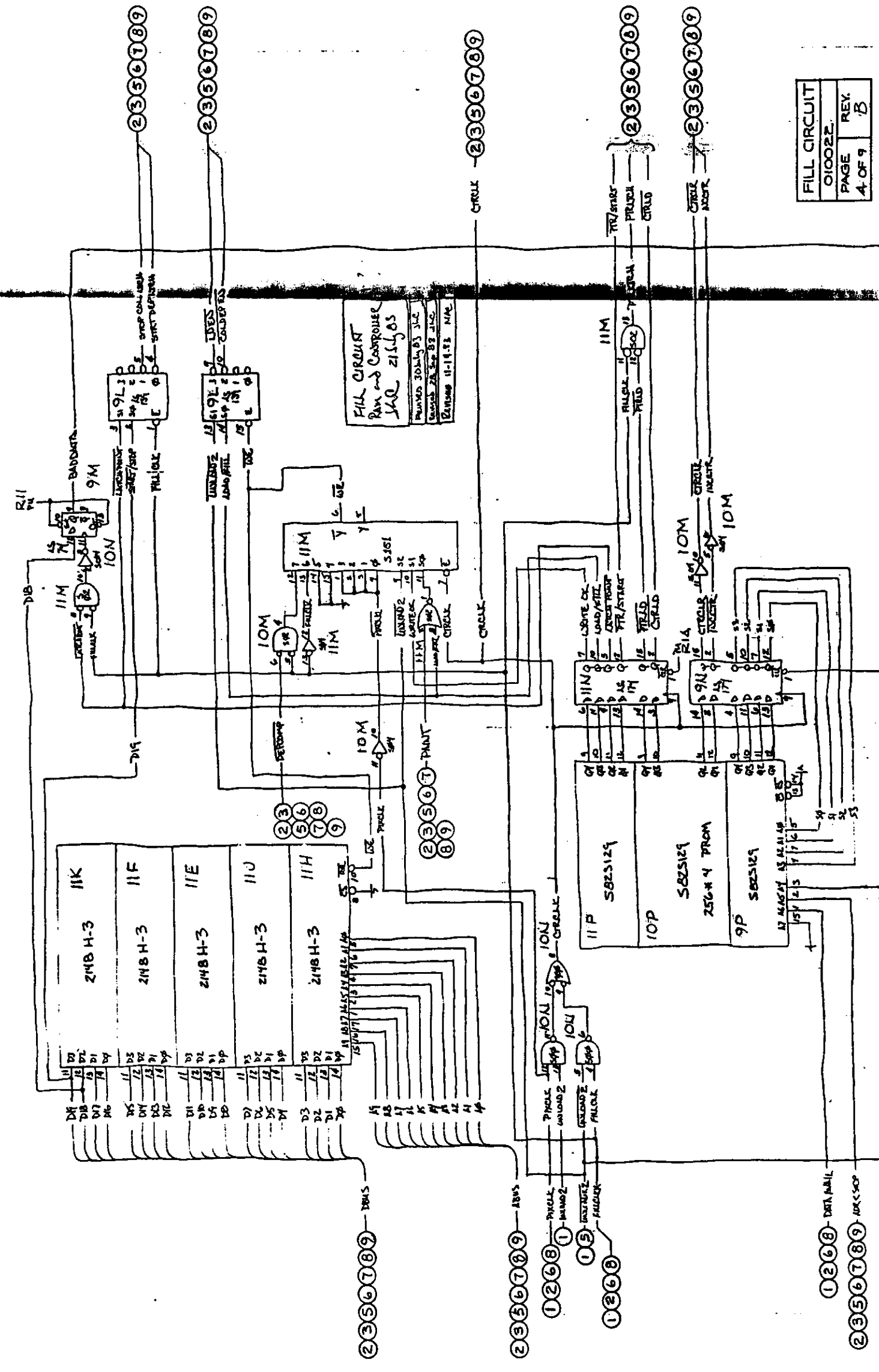

FILL CIRCUIT
 RAM and Controller
 HQ 2154 AS
 DRAWN 30 JUN 83 JLC
 REVISED 28 SEP 88 JLC
 PARTNO 11-19.33 N/A

FILL CIRCUIT	
010022	
PAGE	REV.
4 OF 9	B

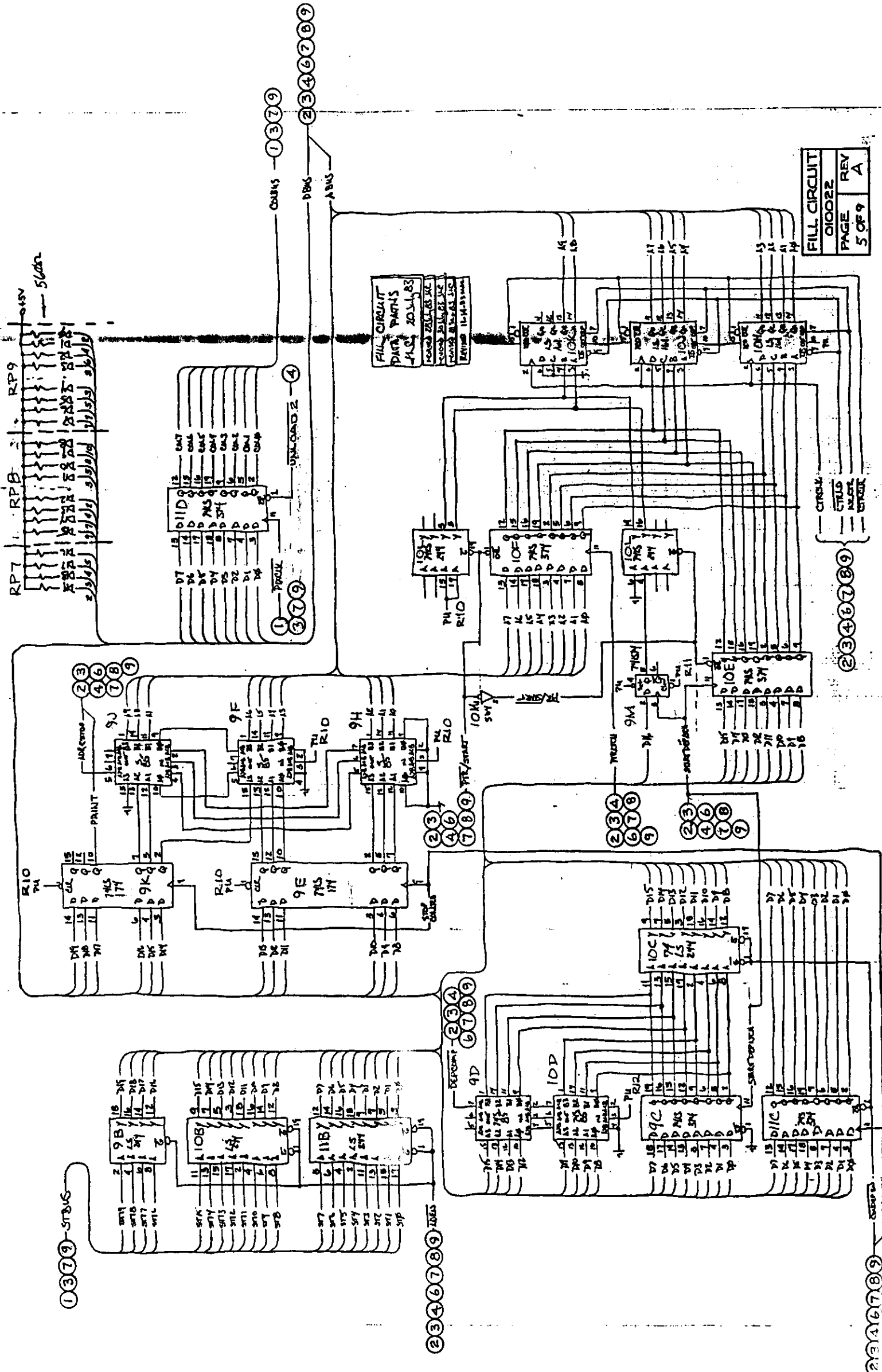

FILL CIRCUIT
 Q1002
 PAGE 5 OF 9
 REV A

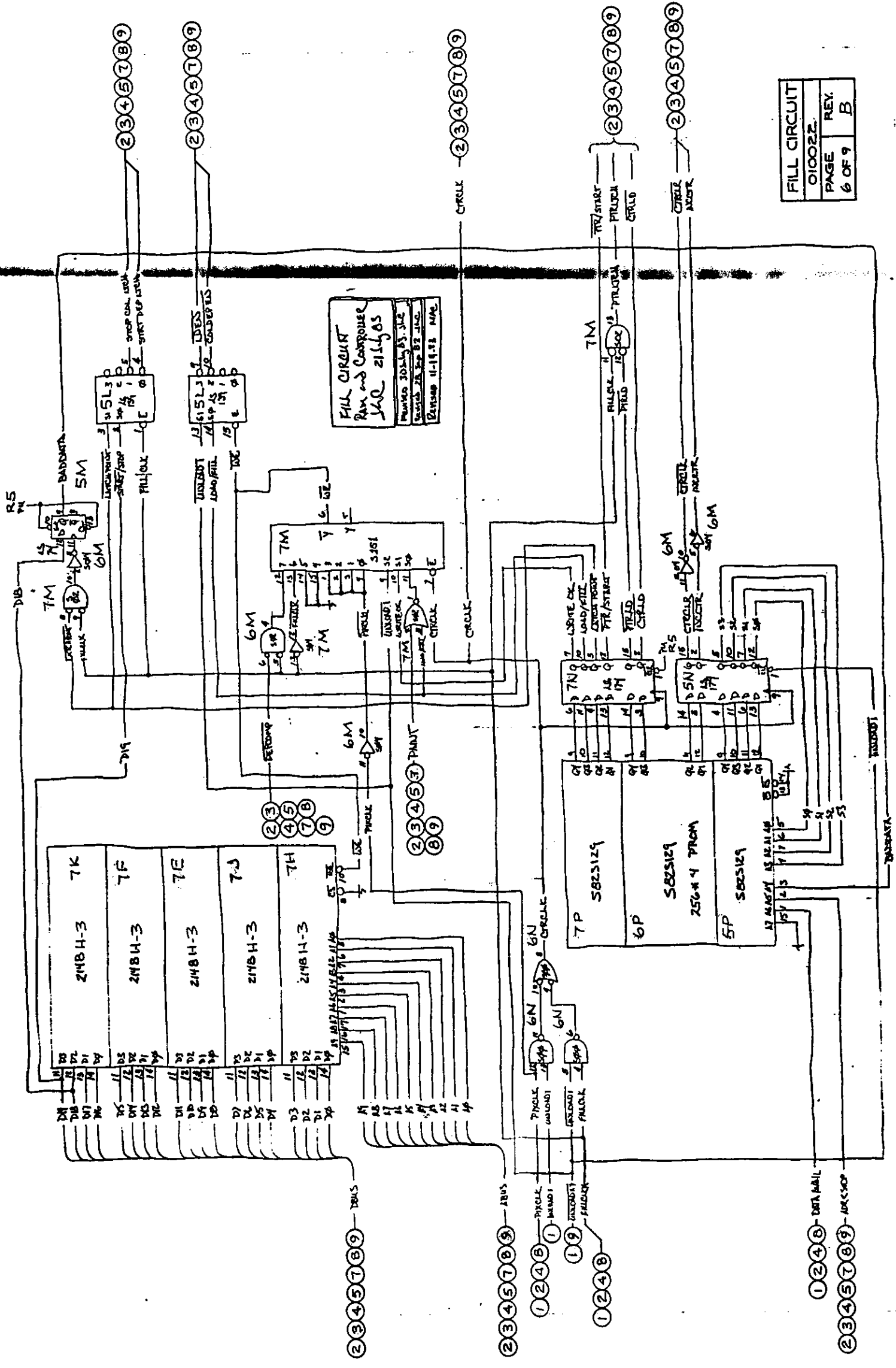

FILL CIRCUIT
RAM and COMPRESSOR
JAC 211405
PRINTED 20/10/63 JAC
REVISED 28/10/63 JAC
DESIGNED 11/11/63 MAB

FILL CIRCUIT	
010022	
PAGE	REV.
6 OF 9	B

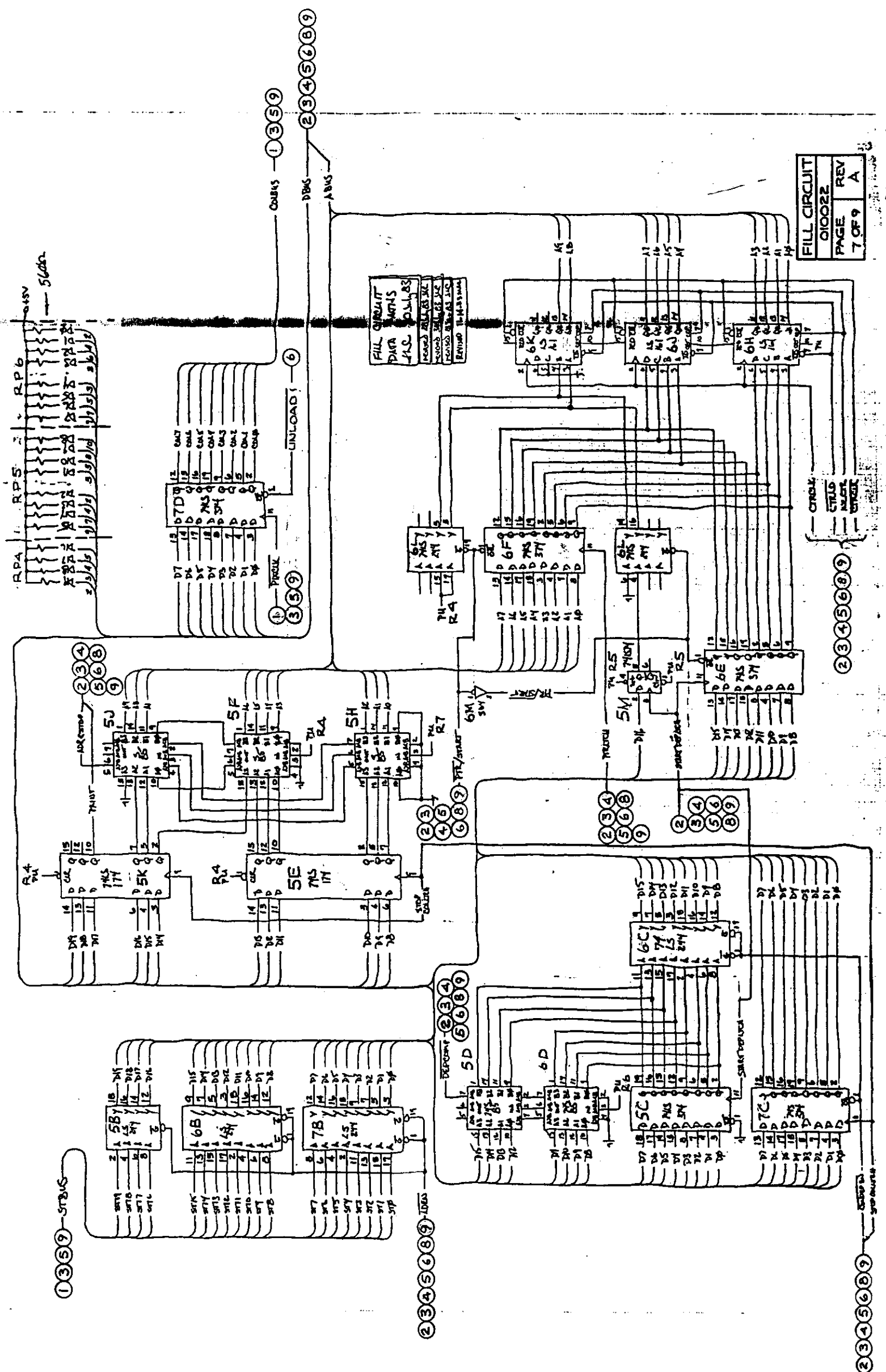

FILL CIRCUIT		
C10022		
PAGE	REV	A
7 OF 9		

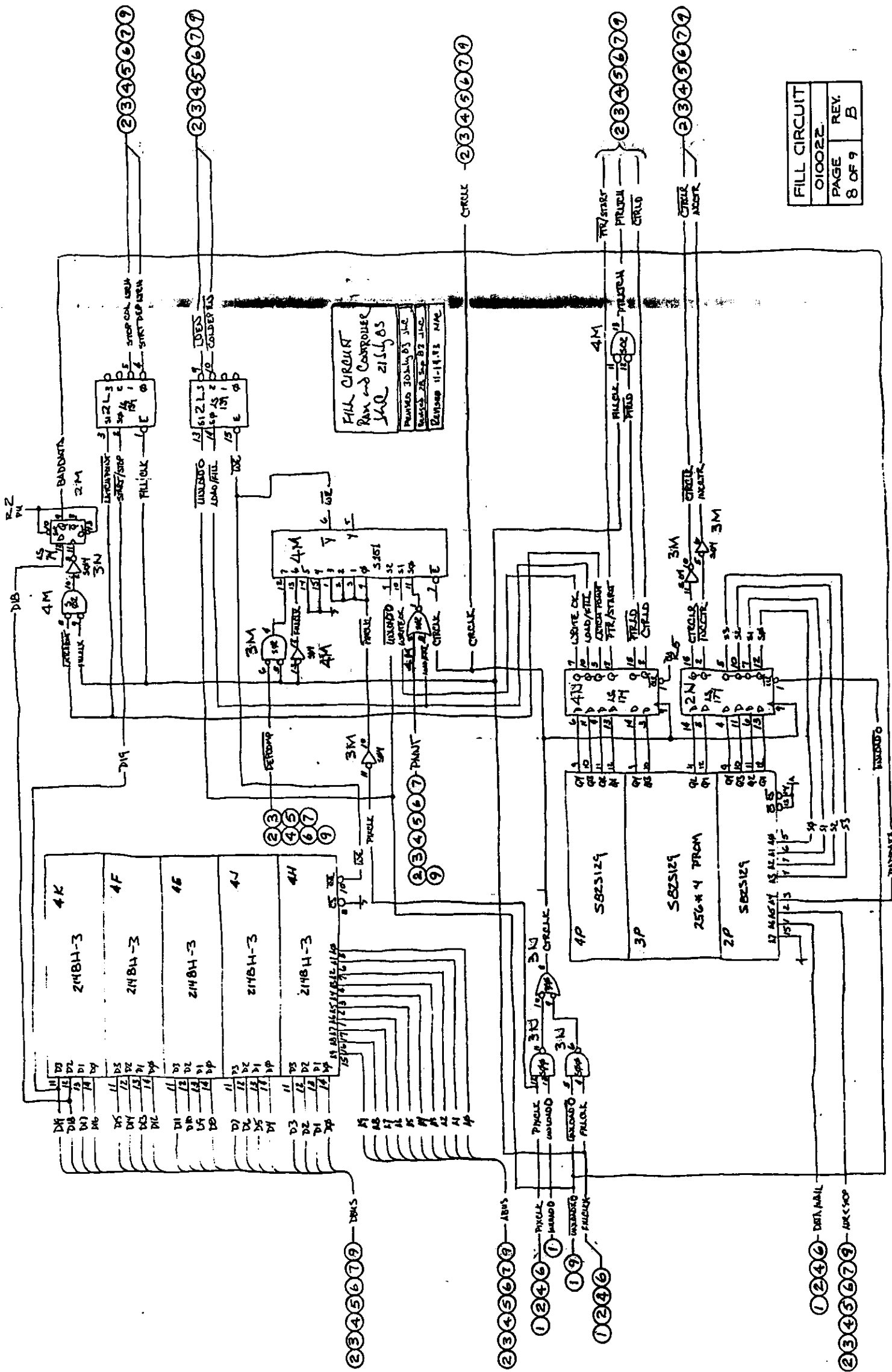

FILL CIRCUIT		
O1002Z		
PAGE	8 OF 9	REV. B

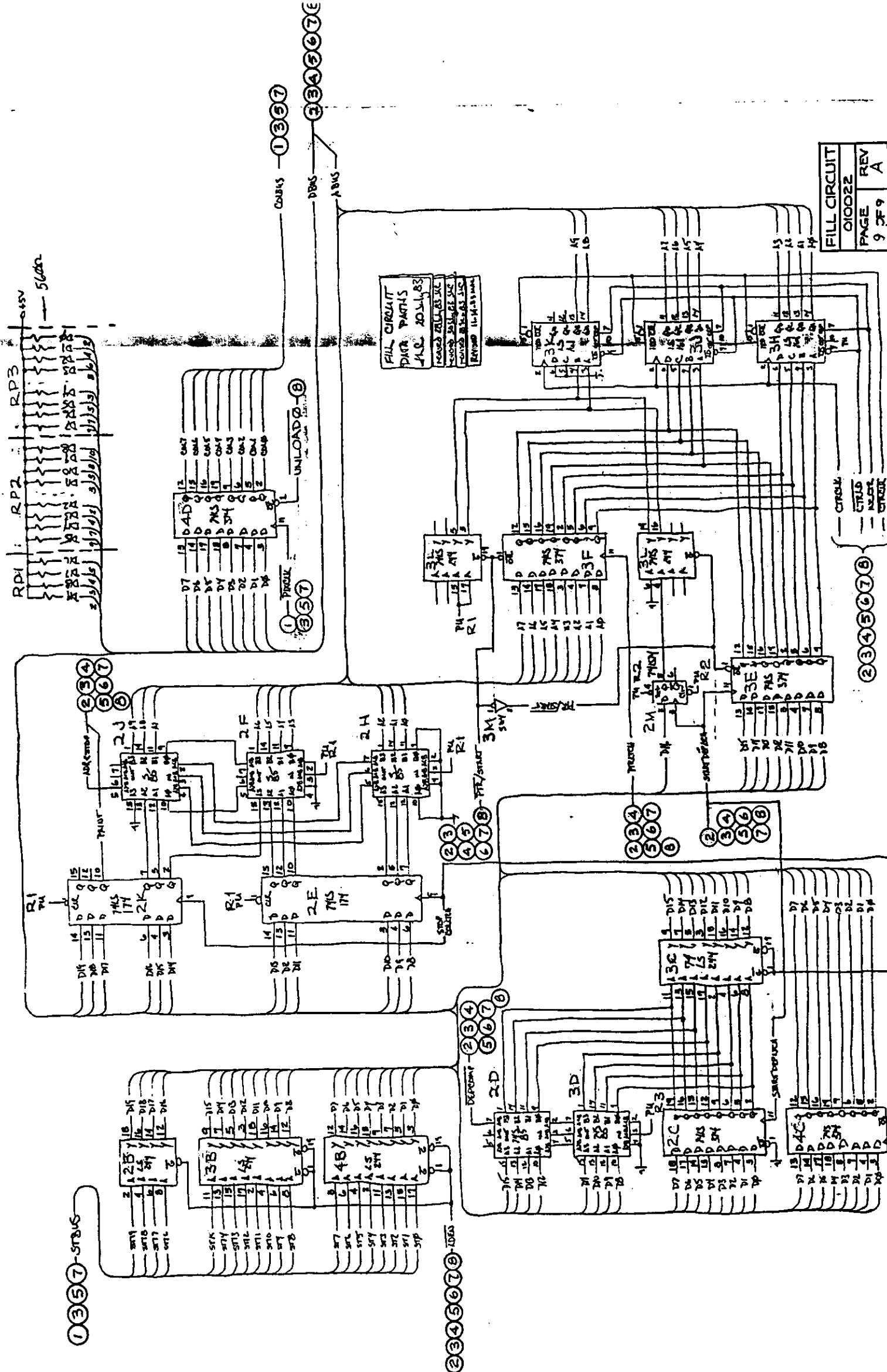

1357-STATUS

2345678-DBUS

2345678-CONTROL
 --- DATA
 --- ADDRESS

_J2 ADDRESS

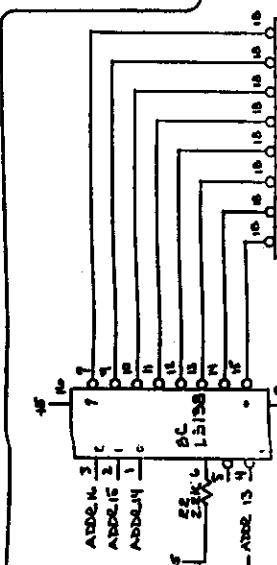
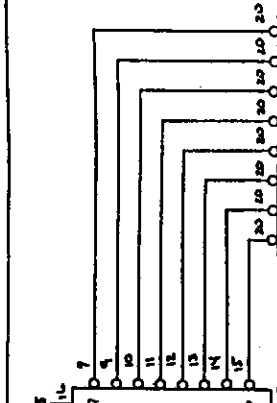
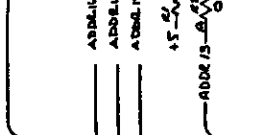
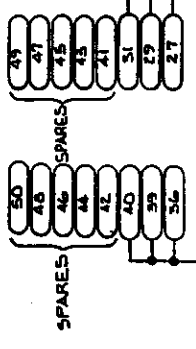

_J5 POWER

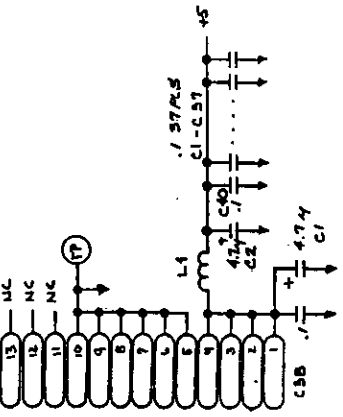

_J1 DATA

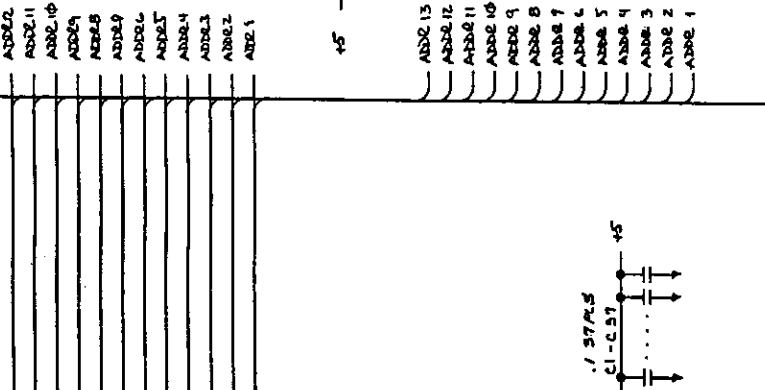
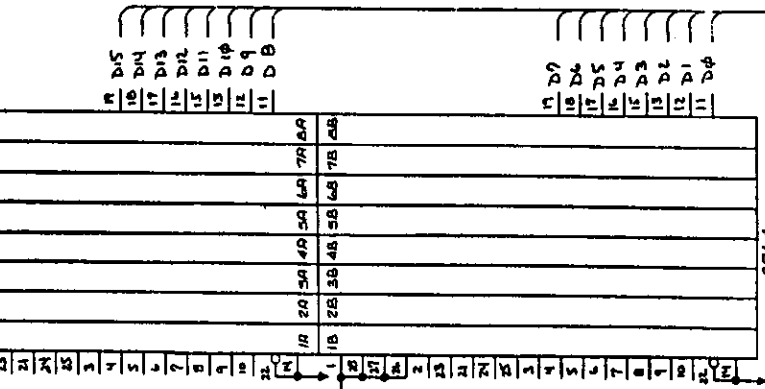
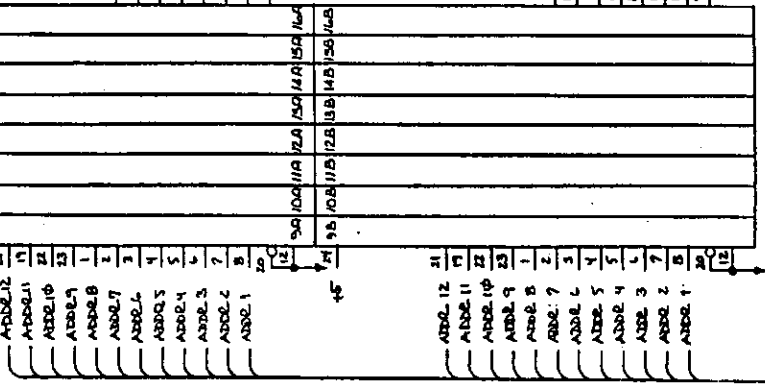
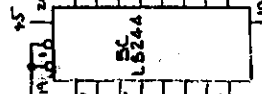
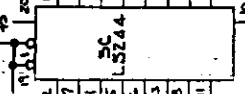
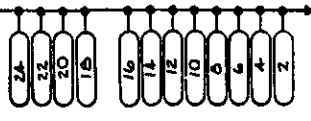
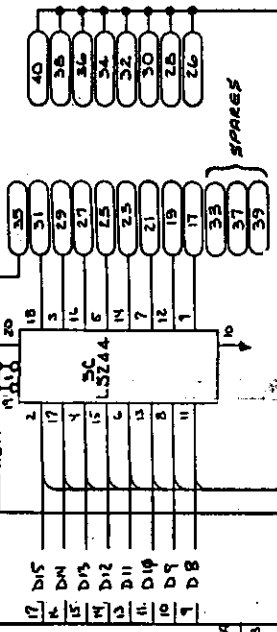

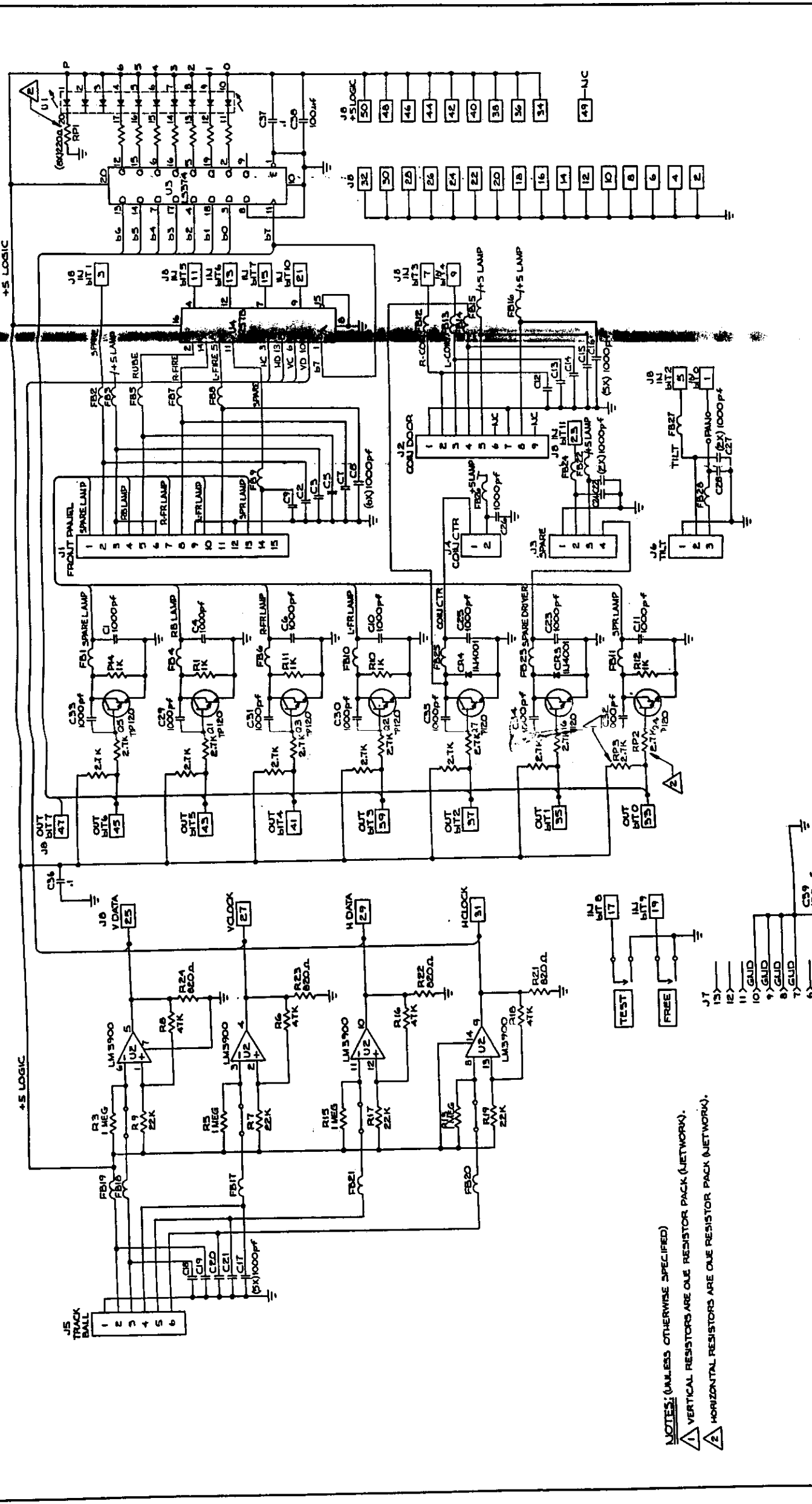

NOTES: (UNLESS OTHERWISE SPECIFIED)
 1 VERTICAL RESISTORS ARE ONE RESISTOR PACK (NETWORK).
 2 HORIZONTAL RESISTORS ARE ONE RESISTOR PACK (NETWORK).

REVISIONS			
LTR	DESCRIPTION	DATE	APPD
A	PRODUCTION RELEASE		
B	REVISED PER BUG INSTRUCTION		

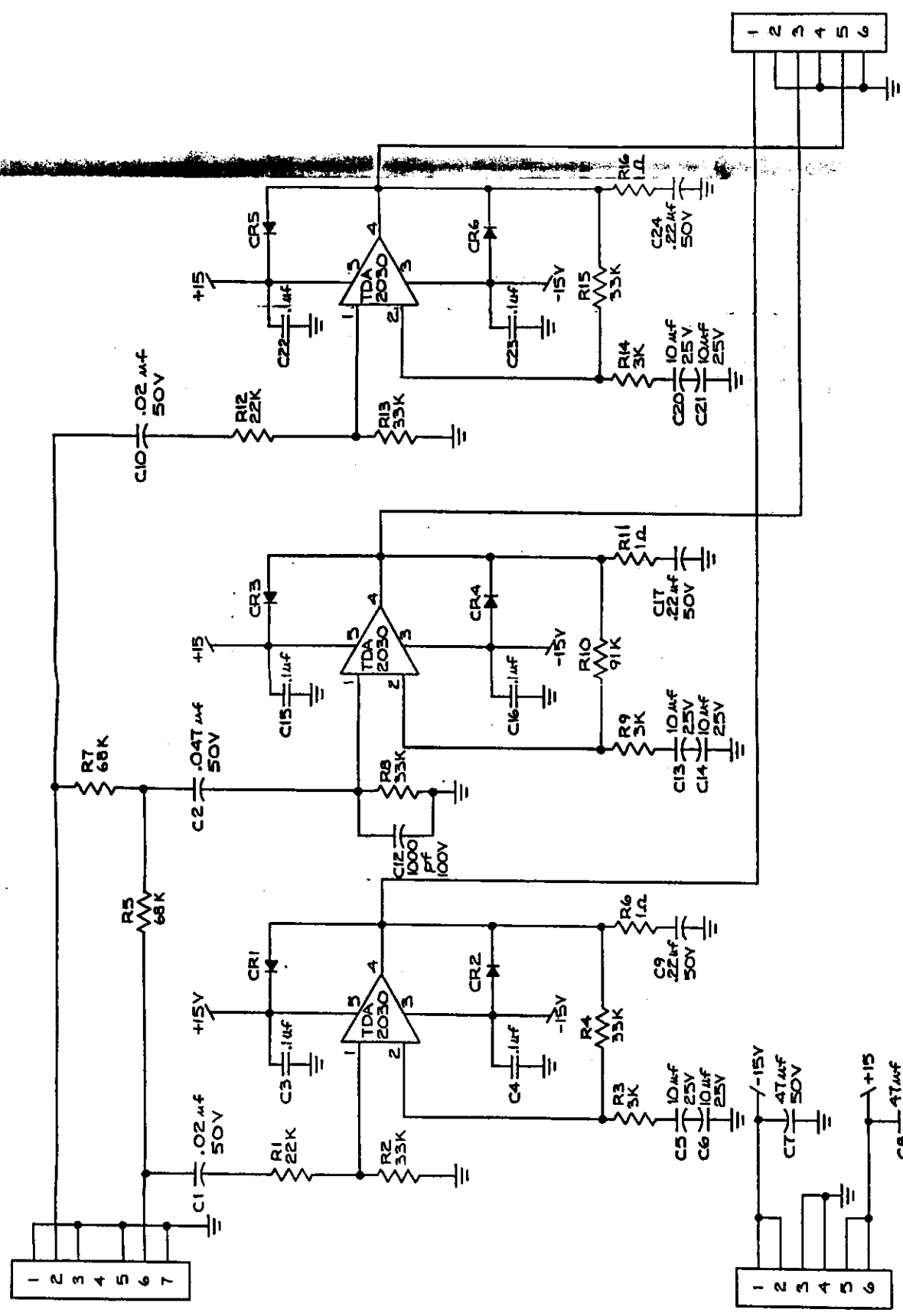

NOTES: (UNLESS OTHERWISE SPECIFIED)

- ALL RESISTORS ARE 1/4W AND 5%.
- ALL DIODES ARE 1N4002.
- LM1875T MAYBE INTERCHANGE WITH TDA2030.

SIMUTREK, INC.	
SCALE: DATE: 11-27-83	APPROVED BY: NTPERALTA
AUDIO AMPLIFIER	
N/A 010033	010034B

PRINTED WIRING MASTER 010031
 PRINTED WIRING ASSEMBLY 010033
 PRINTED WIRING BOARD 010032

REV	DESCRIPTION	DATE	APPROVED
B	PRODUCTION RELEASE		

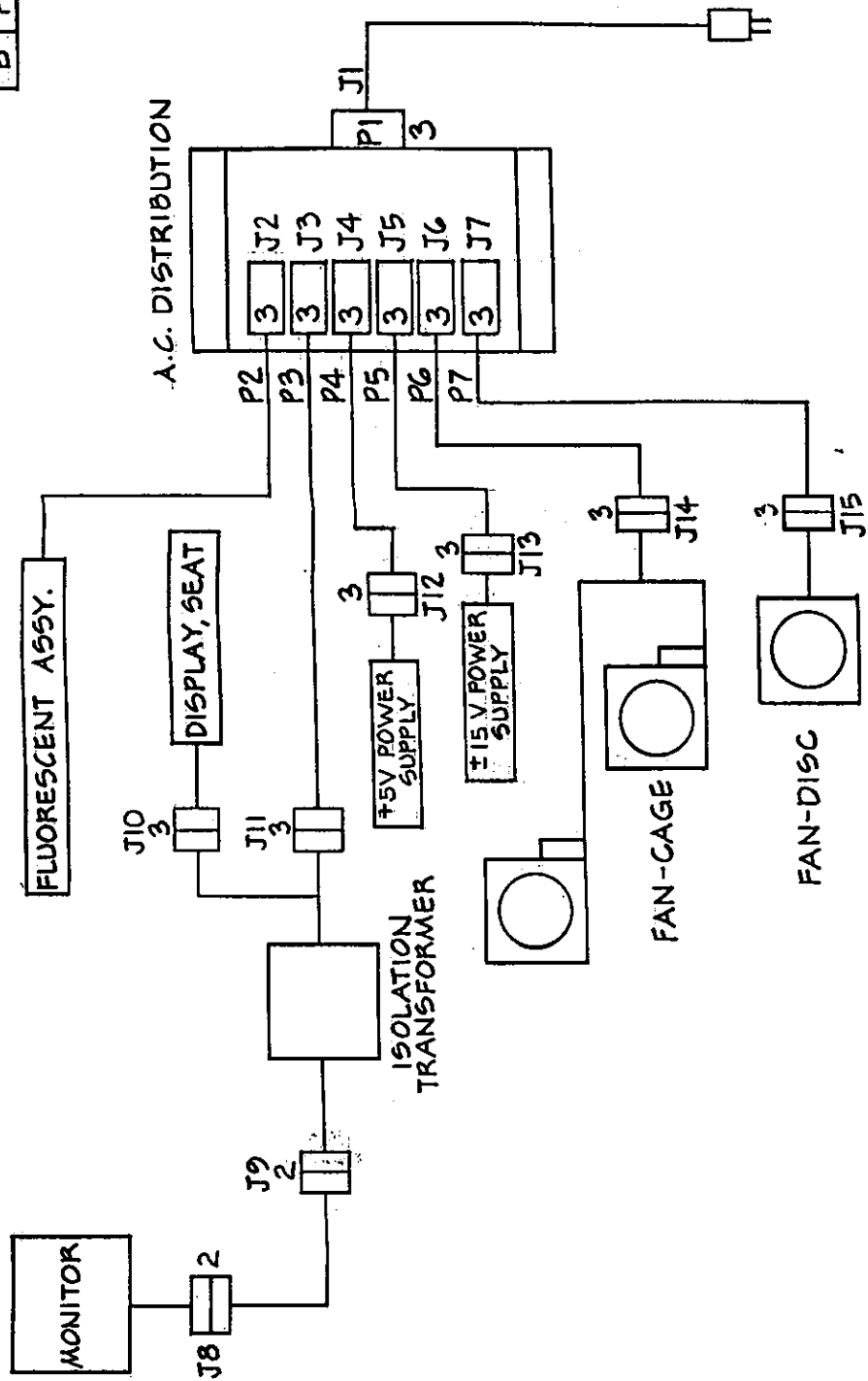

QTY		FSCM NO.		PART OR IDENTIFYING NO.		NOMENCLATURE OR DESCRIPTION		MATERIAL SPECIFICATION	
PARTS LIST									
CONTRACT NO.					SIMUTREK, INC.				
UNLESS OTHERWISE SPECIFIED DIMENSIONS ARE IN INCHES TOLERANCES ARE:					CABLE DIAGRAM, AC				
±		/ .XX ±		/ .XXX ±		ANGLES ±		DATE	
								11-25-83	
DRAWN C & M					APPROVALS				
CHECKED					ISSUED				
MATERIAL					SCALE NONE				
FINISH					DWG. NO. 010149				
NEXT ASSY					REV. B				
APPLICATION					SHEET 1 OF 1				
DO NOT SCALE DRAWING									

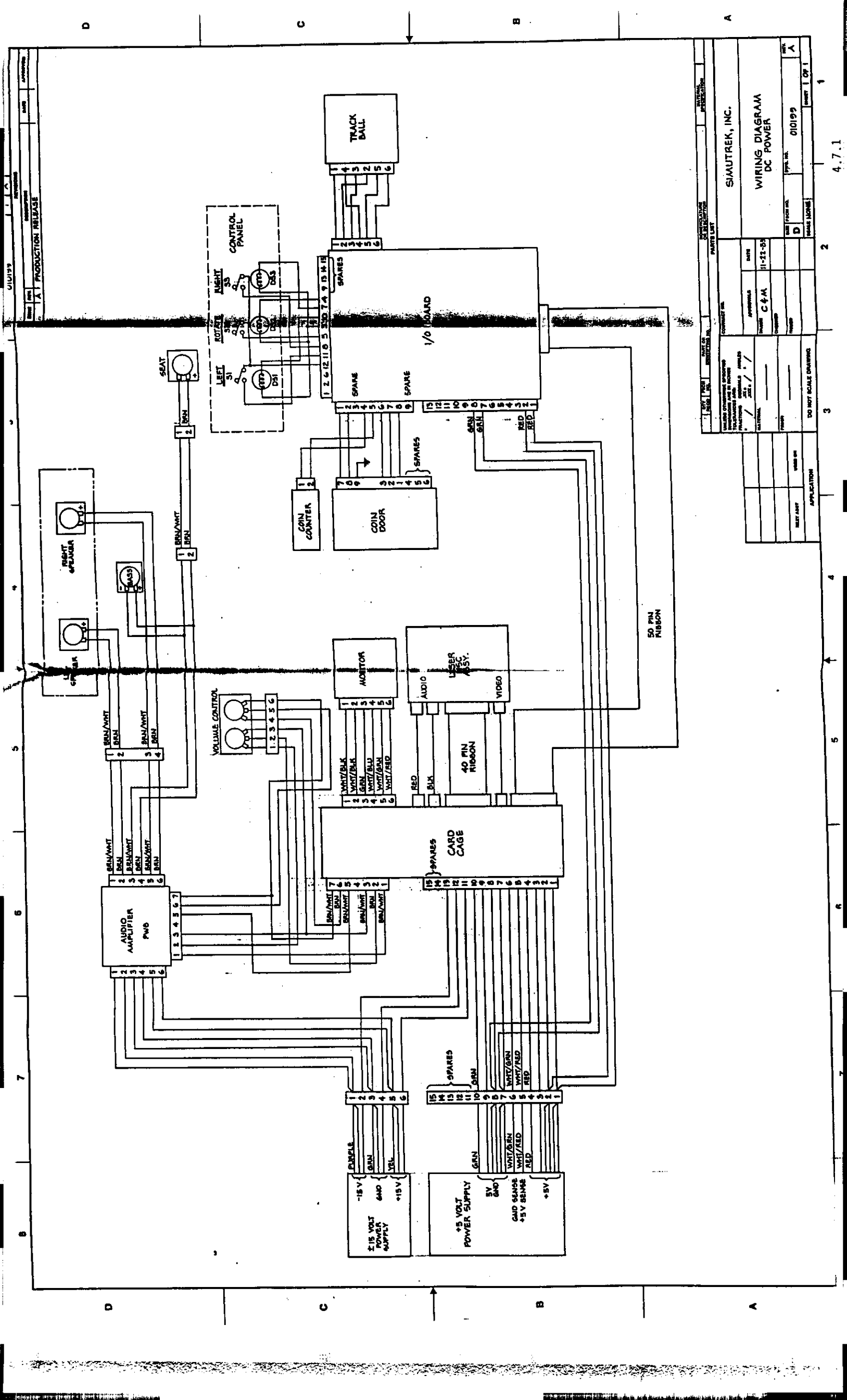

1 2 3 4 5 6 7 8

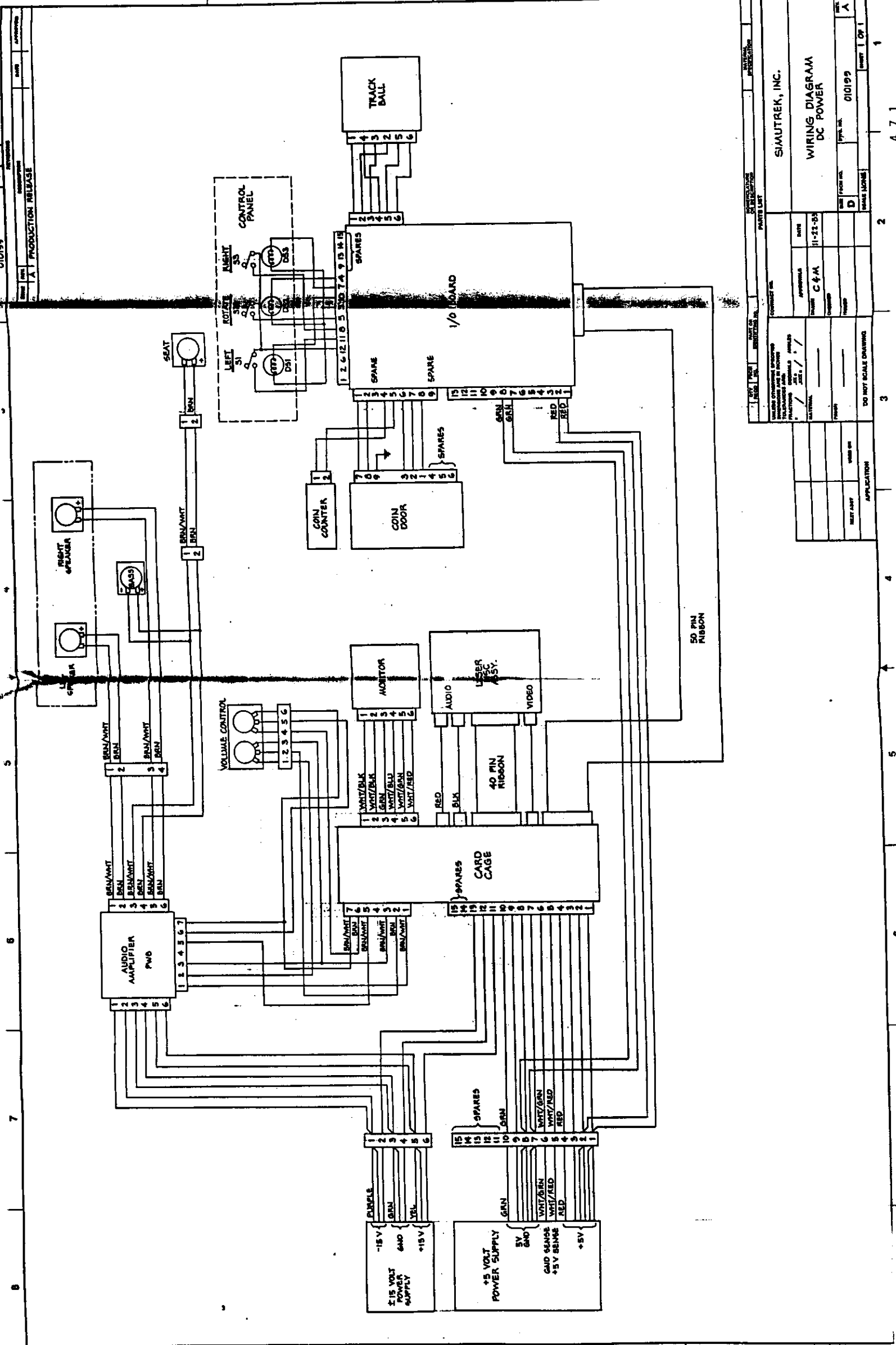

9 10 11 12 13 14 15 16 17 18 19 20 21 22 23 24 25 26 27 28 29 30 31 32 33 34 35 36 37 38 39 40 41 42 43 44 45 46 47 48 49 50 51 52 53 54 55 56 57 58 59 60 61 62 63 64 65 66 67 68 69 70 71 72 73 74 75 76 77 78 79 80 81 82 83 84 85 86 87 88 89 90 91 92 93 94 95 96 97 98 99 100

REV. NO.		REV. DATE		REV. BY		REV. CHECK		REV. APPROVED	
1		2		3		4		5	
SIMUTREK, INC. WIRING DIAGRAM DC POWER									
DATE: 11-22-58 APPROVED: C.F.M. DRAWN: J.E.S. / J.E.S.									
PART NO. 010199 SHEET NO. 1 OF 1									

DO NOT SCALE DRAWING		APPLICATION	
DATE	BY	DATE	BY

REVISIONS		
LTR	DESCRIPTION	DATE APPD
A	PRODUCTION RELEASE	
B	REVISED PER ENGINEERING INSTRUCTION	
C	REVISED PER ENGINEERING INSTRUCTION	
D	REVISED PER ENGINEERING INSTRUCTION	

FOR LIST OF MATERIAL, SEE PL 010017

DATE: 11-25-83	BY: J. J. [unclear]	REV: 02
MOTHER / SOUNDS		
N/A	010014	REV: 02
		ACCOIT D
		SRT 1 OF 3

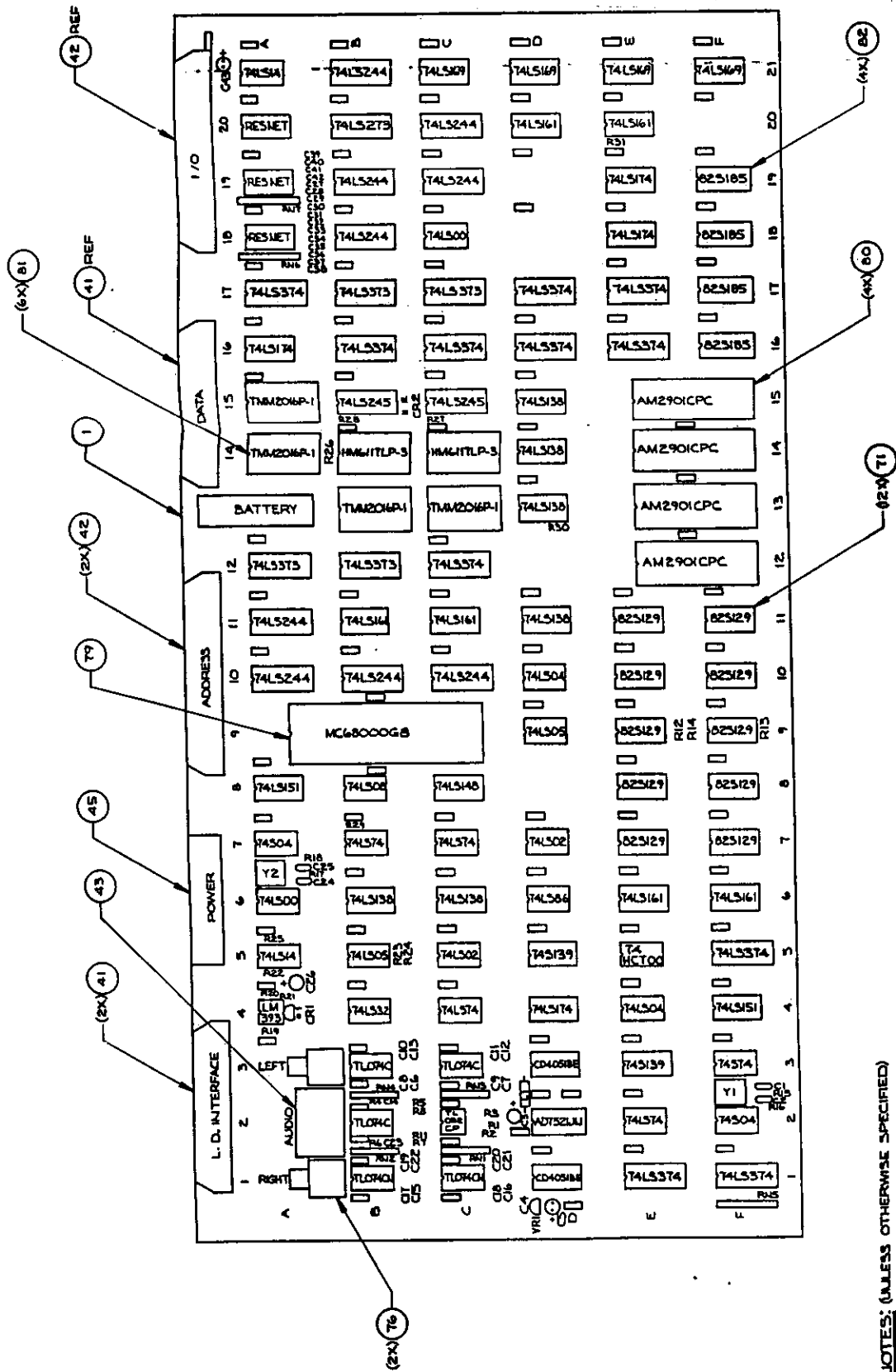

- NOTES: (UNLESS OTHERWISE SPECIFIED)**
1. RELATED DOCUMENTS ARE: 1. COMPONENT REFERENCE LIST 010017
 2. PARTS LIST 010017
 3. PRINTED WIRING MASTER 010016
 4. PRINTED WIRING BOARD 010016
 5. LOGIC DIAGRAM 010016
2. DRILLS ARE TO BE DONE PRIOR TO ANY ASSEMBLY.

D C B A

REV	DESCRIPTION	DATE
A	PRODUCTION RELEASE	
B	REVISED PER ENGINEERING INSTRUCTION	
C	REVISED PER ENGINEERING INSTRUCTION	

AD10029

1 2 3 4 5 6 7 8

1

3

4

5

6

7

8

1

2

3

4

5

6

7

8

1

2

3

4

5

6

7

8

1

2

3

4

5

6

7

8

1

2

3

4

5

(1X) (13)
 (25, 30, 31, 32, 33, 34, 35, 36, 37, 38, 39, 40, 41, 42, 43, 44, 45, 46, 47, 48, 49, 50, 51, 52, 53, 54, 55, 56, 57, 58, 59, 60, 61, 62, 63, 64, 65, 66, 67, 68, 69, 70, 71, 72, 73, 74, 75, 76, 77, 78, 79, 80, 81, 82, 83, 84, 85, 86, 87, 88, 89, 90, 91, 92, 93, 94, 95, 96, 97, 98, 99, 100)

(16X) (30)
 (12C-K, 107, 108, 109, 110, 111, 112, 113, 114, 115, 116, 117, 118, 119, 120, 121, 122, 123, 124, 125, 126, 127, 128, 129, 130, 131, 132, 133, 134, 135, 136, 137, 138, 139, 140, 141, 142, 143, 144, 145, 146, 147, 148, 149, 150, 151, 152, 153, 154, 155, 156, 157, 158, 159, 160, 161, 162, 163, 164, 165, 166, 167, 168, 169, 170, 171, 172, 173, 174, 175, 176, 177, 178, 179, 180, 181, 182, 183, 184, 185, 186, 187, 188, 189, 190, 191, 192, 193, 194, 195, 196, 197, 198, 199, 200)

(3X) (60)
 (1)

(61)

(64)

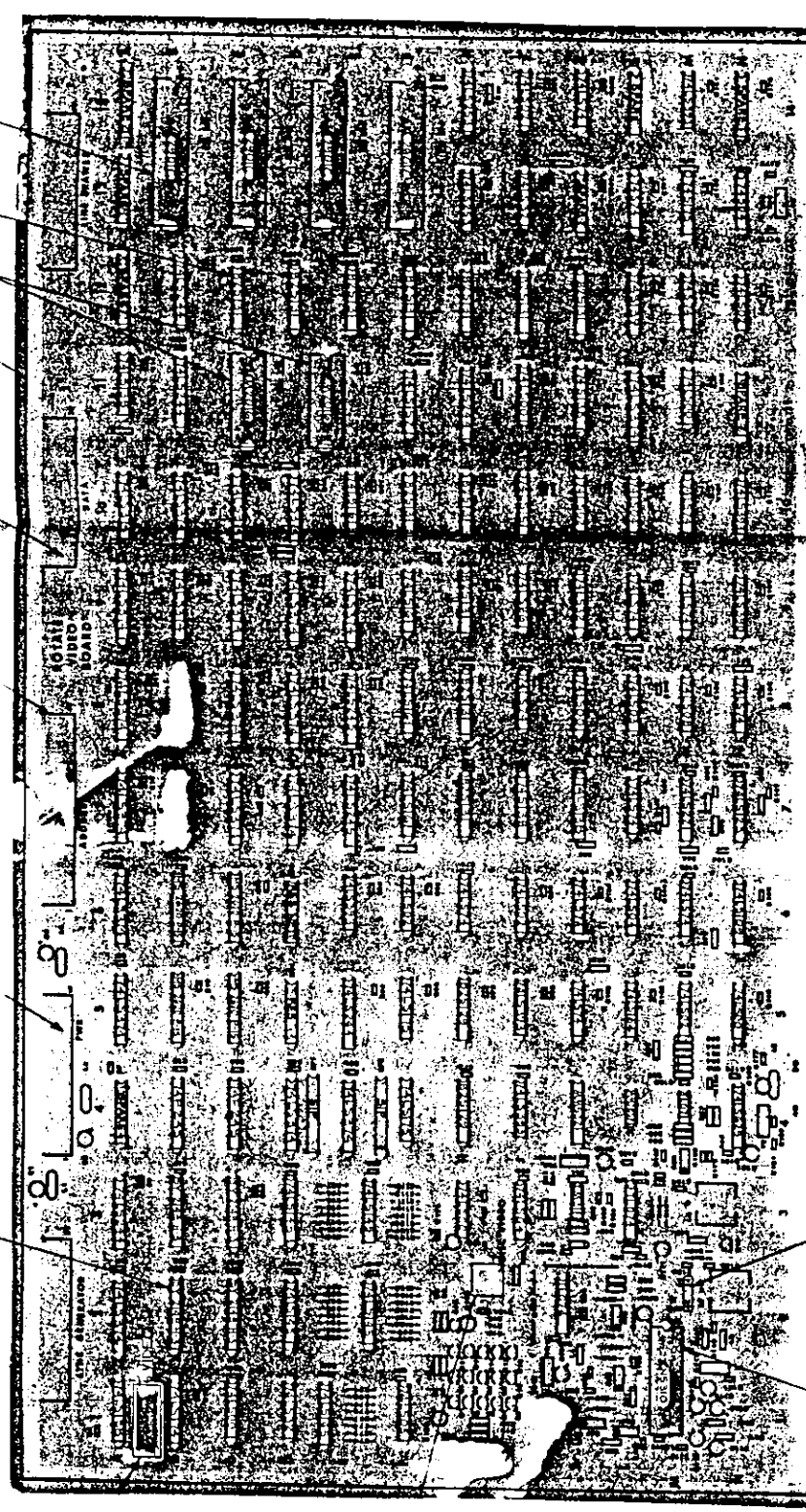

(12)

(126)

(137) (13X) (04)

NOTES: (UNLESS OTHERWISE SPECIFIED)

1. RELATED DOCUMENTS ARE: 1. COMPONENT REFERENCE LIST (100) 29
2. PARTS LIST (100) 29
3. PRINTED WIRING BOARD (100) 78
4. LOGIC FUNCTIONAL (100) 78

PARTS LIST		DATE	
1	11-26-63	12	11-19-64
SEI PARTS LIST		C.G.M.	
DO NOT SCALE DRAWING		UNIT ON APPLICATION	
SIMUTREK, INC.		PRINTED WIRING AS ROTATE VILIED	
AD10029		REV. 1-3	

REVISIONS	DESCRIPTION	DATE	APPRO
1	FOR REVISION STATUS SEE SHEET 1		

SIMUTREK, INC.	
PRINTED WIRING ASSY.	
ROTATE VIDEO	
REV	1 C
REV	1 C
REV	1 C

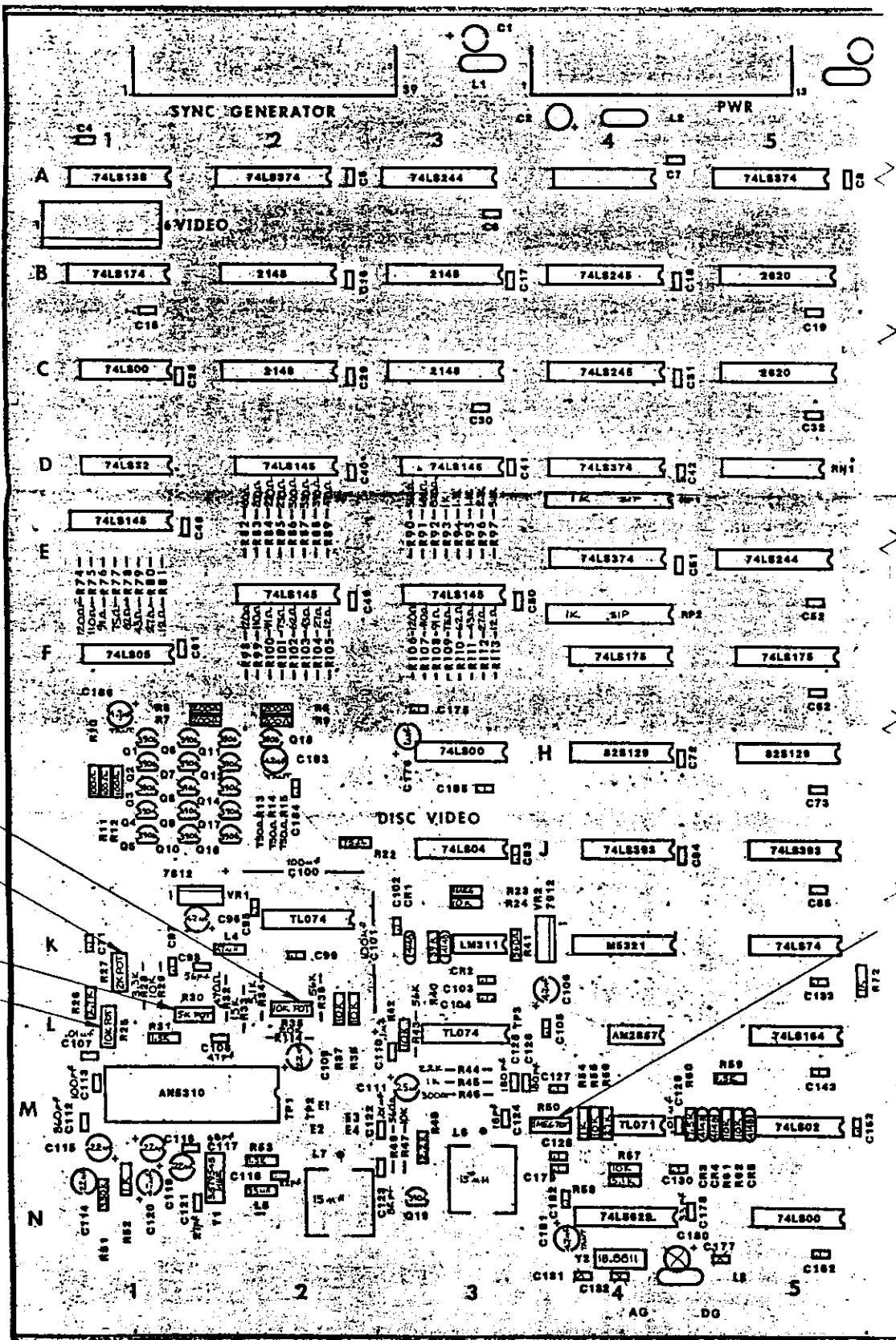

CONTRAST ADJUSTMENT
 TINT ADJUSTMENT
 COLOR ADJUSTMENT
 BRIGHTNESS ADJUSTMENT

COMPONENT SIDE
 HORIZONTAL PHASE ADJUSTMENT

REVISIONS

LTR	DESCRIPTION	DATE	APPROV
A	PRODUCTION RELEASE	4/16/83	[Signature]
B	REVISED PER ENGINEERING INSTRUCTION		

FOR LIST OF MATERIAL SEE PL 010025

SIMUTREK INC.	
PRINTED WIRING ASSEMBLY	
DRAWER	
REVISED BY	REVISED DATE
AW7088	12-14-83
REVISED BY	
AW7088	
REVISED DATE	
12-14-83	
REVISED BY	
AW7088	
REVISED DATE	
12-14-83	

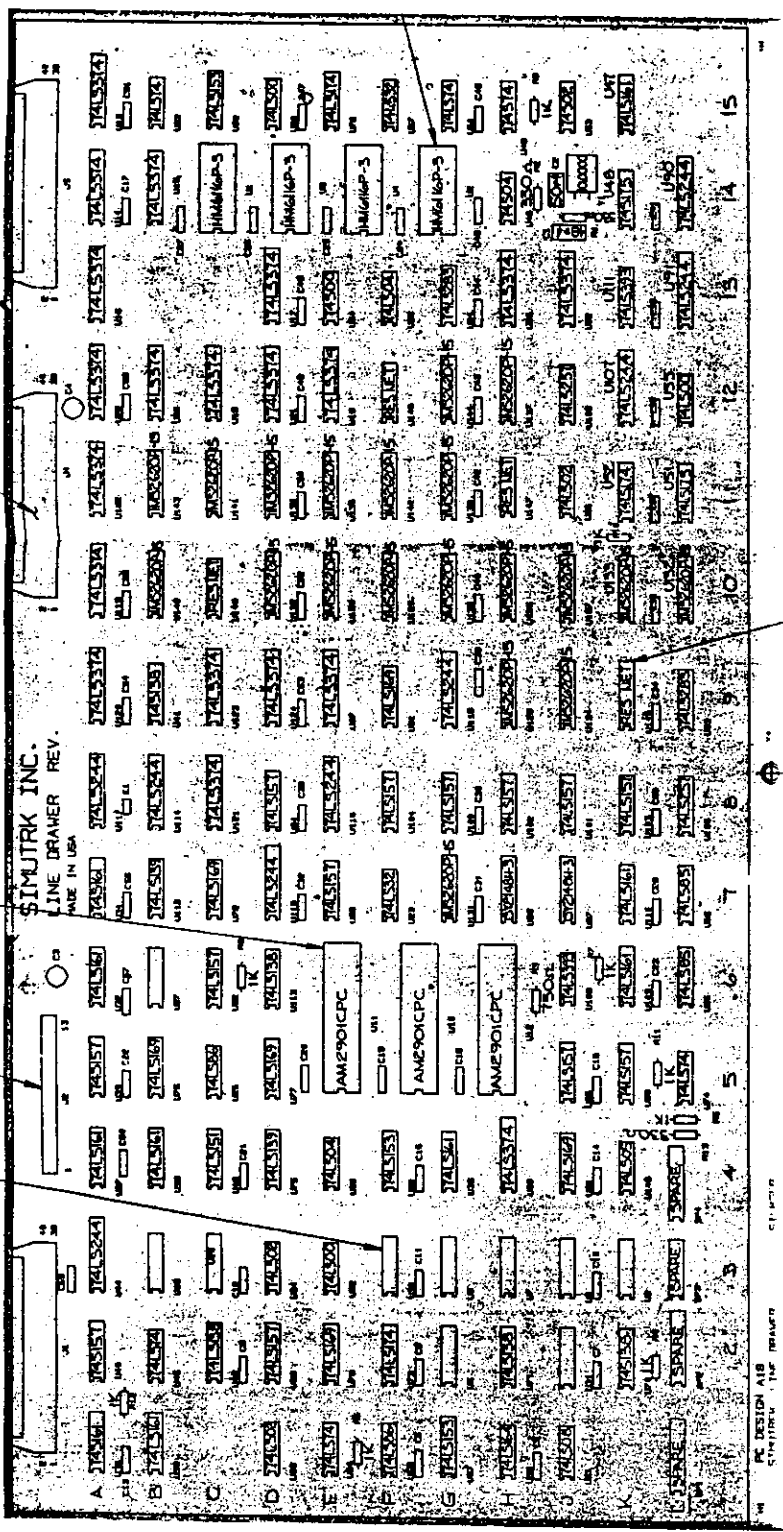

(3X)(35)

(5X)(50)
(UO.11.12)
REF

(11X)(53)
(11X)(53)
REF

SIMUTREK INC.
LINE DRAWER REV.
MADE IN USA

PC DESIGN A18
CIRCUIT BOARD

NOTES: (VALUES OTHERWISE SPECIFIED)

1. RELATED DOCUMENTS ARE: 1. COMPONENT REFERENCE LIST 01002; 2. PARTS LIST 01002; 3. LOGIC DIAGRAM 01002; 4. PRINTED WIRING MASTER 01002; 5. PRINTED WIRING BOARD 01002.

REV	NO	DESCRIPTION	DATE	APPROVED
X	A	PRODUCTION RELEASE		
X	B	REVISED PER ENGINEERING INSTRUCTION		
X	C	REVISED PER ENGINEERING INSTRUCTION		
X	D	REVISED PER ENGINEERING INSTRUCTION		

FIG NO: A010021

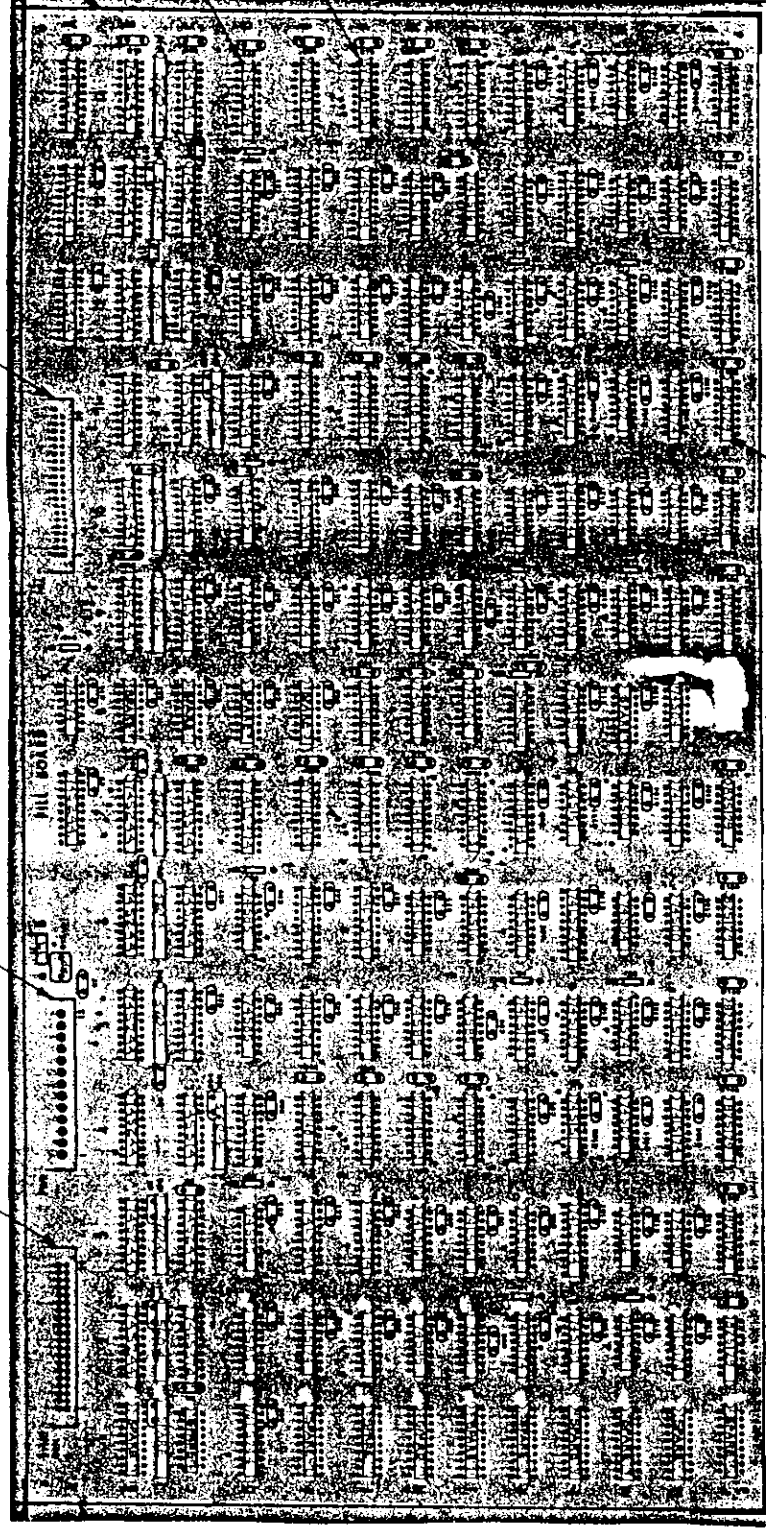

FOR LIST OF MATERIAL SEE PL 010021

(2X) 32
(2P-7P, 9P-14P)
REF

(EX) 14

17

14 REF

33

(1) TD, 11D, 14D)

32

E-4K, 7E-TK, 11E-11K, 14E-14K)

REV	NO	DESCRIPTION	DATE	APPROVED
X	A	PRODUCTION RELEASE		
X	B	REVISED PER ENGINEERING INSTRUCTION		
X	C	REVISED PER ENGINEERING INSTRUCTION		
X	D	REVISED PER ENGINEERING INSTRUCTION		

DATE: 11-26-83
BY: CEM
CHECKED: [Signature]
DATE: 12-12-83
BY: [Signature]

COMPANY: SIMUTREK, INC.
DRAWING: PRINTED WIRING ASSEMBLY
FILL: [Blank]
PART NO: A010021
SHEET: 1 OF 3

010006	UNIT ON	APPLICATION

NOTES: (UNLESS OTHERWISE SPECIFIED)

1. RELATED DOCUMENTS ARE: 1. COMPONENT REFERENCE LIST 010021
2. PARTS LIST 0KX21
3. PRINTED WIRING MASTER 010019
4. PRINTED WIRING BOARD 010020
5. LOGIC DIAGRAM 010022

DO NOT SCALE DRAWING

SCALE: [Blank]

UNIT ON: [Blank]

APPLICATION: [Blank]

APPROVED: _____ DATE: _____ A PRODUCTION RELEASE		PART NUMBER: _____ DESCRIPTION: _____ ITEM NO: _____	PARTS LIST DATE: 12-23-85 BY: M. PERALTA CHECKED: _____ PROJECT NUMBER: _____ DO NOT SCALE DRAWING	SIMULTECH, INC. AND ASSOCIATES PRINTED WIRING ASSEMBLY EPROM BOARD PART NUMBER: AO10012 SHEET: 1 OF 3
---	--	--	---	---

SERIES STANDARD SPECIFICATIONS
 MIL-STD-883C METHOD 2000
 TEST METHOD 2000.10
 SEE PL 010012
 NOTES: (UNLESS OTHERWISE SPECIFIED)

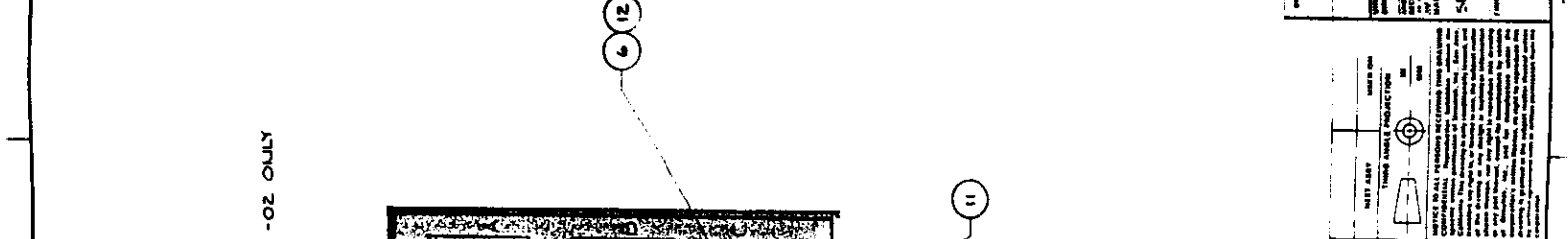

NOTES: (UNLESS OTHERWISE SPECIFIED)
 1. RELATED DOCUMENTS ARE:
 2. PRINTED WIRING MASTER 010010
 3. LOGIC DIAGRAM 010013
 4. PARTS LIST 010012

NOTES: (UNLESS OTHERWISE SPECIFIED)
 1. RELATED DOCUMENTS ARE:
 2. PRINTED WIRING MASTER 010010
 3. LOGIC DIAGRAM 010013
 4. PARTS LIST 010012

NOTES: (UNLESS OTHERWISE SPECIFIED)
 1. RELATED DOCUMENTS ARE:
 2. PRINTED WIRING MASTER 010010
 3. LOGIC DIAGRAM 010013
 4. PARTS LIST 010012

NOTES: (UNLESS OTHERWISE SPECIFIED)
 1. RELATED DOCUMENTS ARE:
 2. PRINTED WIRING MASTER 010010
 3. LOGIC DIAGRAM 010013
 4. PARTS LIST 010012

NOTES: (UNLESS OTHERWISE SPECIFIED)
 1. RELATED DOCUMENTS ARE:
 2. PRINTED WIRING MASTER 010010
 3. LOGIC DIAGRAM 010013
 4. PARTS LIST 010012

NOTES: (UNLESS OTHERWISE SPECIFIED)
 1. RELATED DOCUMENTS ARE:
 2. PRINTED WIRING MASTER 010010
 3. LOGIC DIAGRAM 010013
 4. PARTS LIST 010012

REVISIONS		
LTR	DESCRIPTION	DATE
A	PRODUCTION RELEASE	

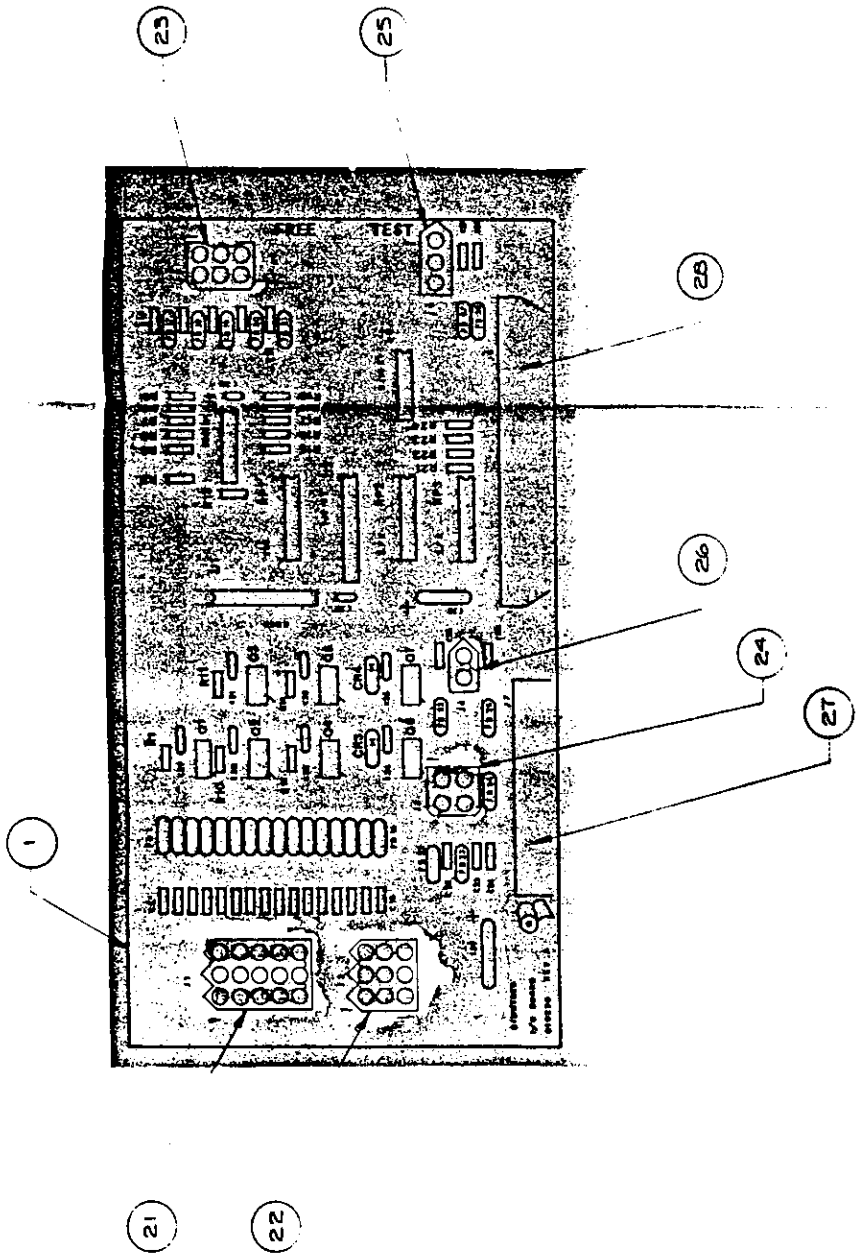

NOTES: (UNLESS OTHERWISE SPECIFIED)

1. RELATED DOCUMENTS ARE: 1. PRINTED WIRING MASTER 010230
 2. PRINTED WIRING BOARD 010231
 3. LOGIC DIAGRAM 010233
 4. PARTS LIST 010232
2. DO NOT STUFF C1 THRU C35

FOR LIST OF MATERIAL SEE PL 010232

SIMUTREK, INC.

SCALE: FULL
 DATE: 11-30-83
 DRAWN BY: N. PERALTA

PRINTED WIRING ASSEMBLY **ip**

REV: A
 SHEET 1 OF 1
 DRAWING NUMBER: A010232

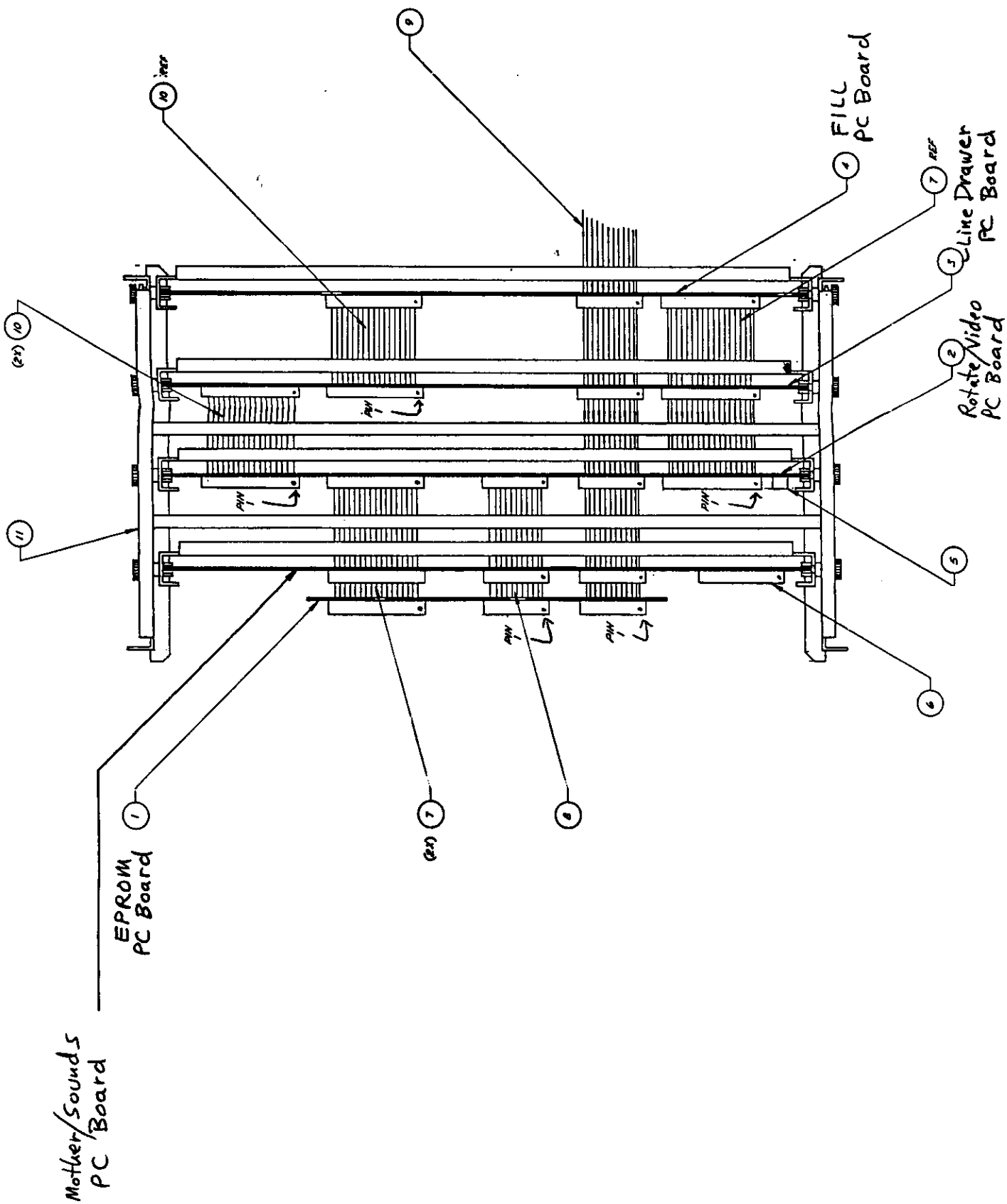

FOR LIST OF MATERIAL SEE PL 010006

REV	DATE	BY	APP'D	DESCRIPTION
1				ELECTRONICS ASSY
2				
3				
4				
5				
6				
7				
8				
9				
10				
11				
12				
13				
14				
15				
16				
17				
18				
19				
20				
21				
22				
23				
24				
25				
26				
27				
28				
29				
30				
31				
32				
33				
34				
35				
36				
37				
38				
39				
40				
41				
42				
43				
44				
45				
46				
47				
48				
49				
50				
51				
52				
53				
54				
55				
56				
57				
58				
59				
60				
61				
62				
63				
64				
65				
66				
67				
68				
69				
70				
71				
72				
73				
74				
75				
76				
77				
78				
79				
80				
81				
82				
83				
84				
85				
86				
87				
88				
89				
90				
91				
92				
93				
94				
95				
96				
97				
98				
99				
100				

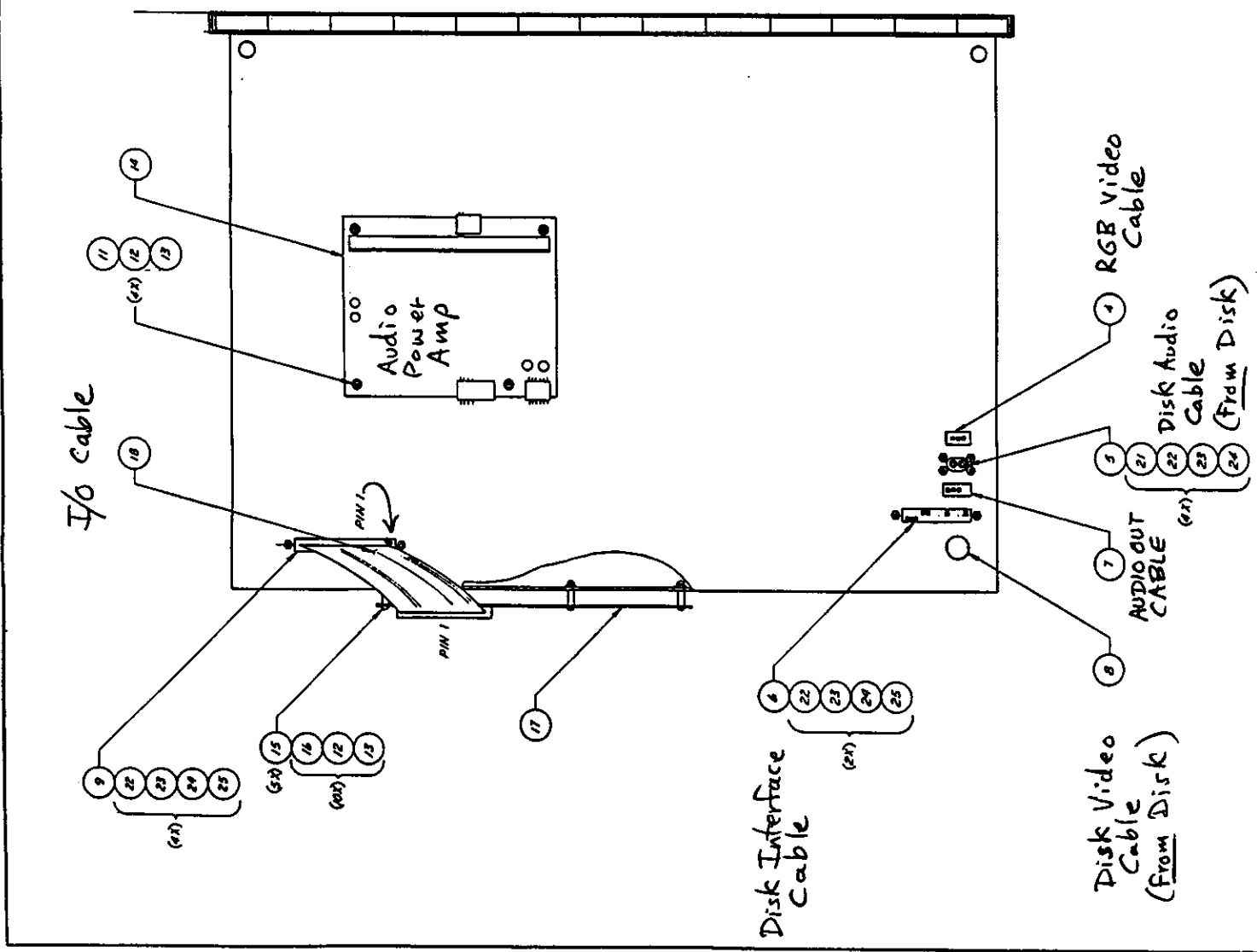
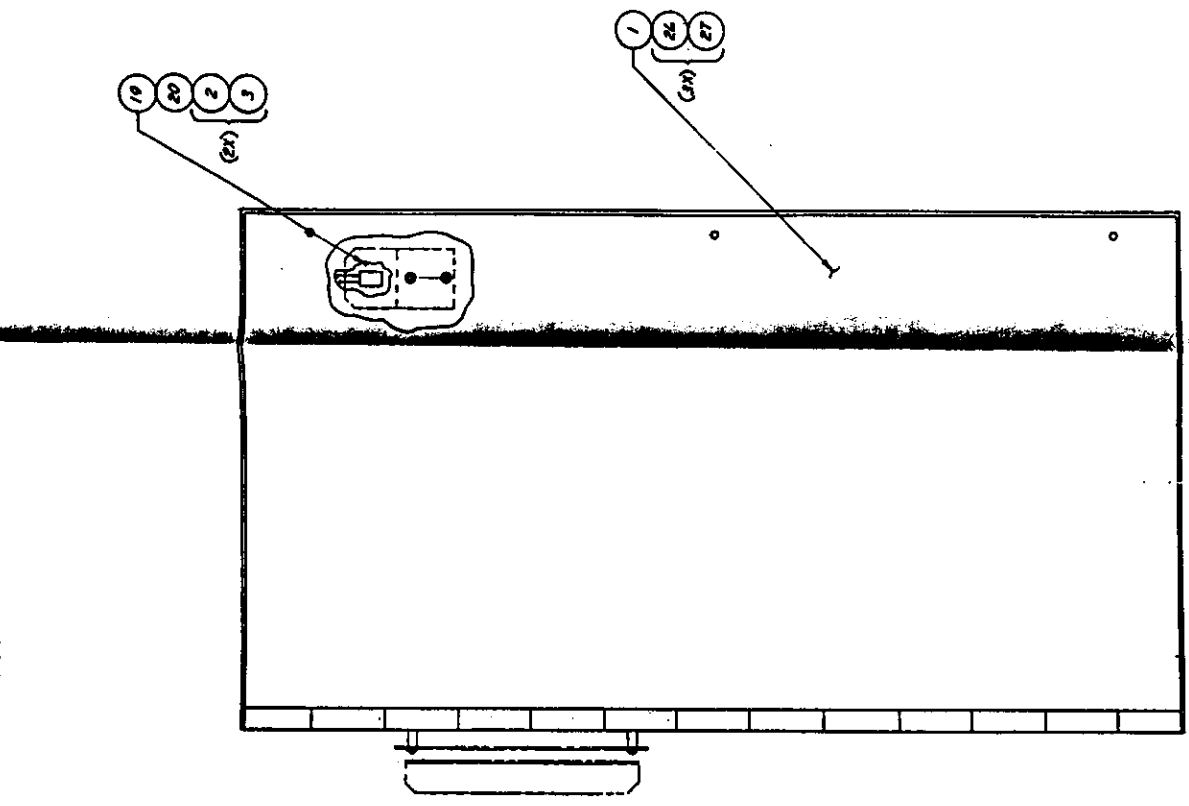

FOR LIST OF MATERIAL SEE PL 010253

REVISIONS		DATE	BY	DESCRIPTION
1				ENCLOSURE ASSY
2				
3				
4				
5				
6				
7				
8				
9				
10				
11				
12				
13				
14				
15				
16				
17				
18				
19				
20				
21				
22				
23				
24				
25				
26				
27				
28				
29				
30				
31				
32				
33				
34				
35				
36				
37				
38				
39				
40				
41				
42				
43				
44				
45				
46				
47				
48				
49				
50				

TITLE: Mother SoundsDWG. NO.: 010017 Rev BSHEET 1 OF 3

COMPONENT REFERENCE LIST

ITEM NO.	DEVICE DESIGNATION	LOCATION
2	74LS00	6A, 18C
3	74LS02	5C, 7D
4	74LS04	4E, 10D
5	74LS08	8B
6	74LS32	4B
7	74LS74	2E, 4C, 7B, 7C,
8	74LS86	6D
9	74LS139	3E, 5D
10	74LS148	8C
11	74LS151	4F, 8A,
12	74LS161	6E, 6F, 11B, 11C, 20D, 20E
13	74LS169	21C, 21D, 21E, 21F
14	74LS174	16A, 18E, 19E, 4D
15	74LS244	10A, 10B, 10C, 11A, 18B, 19B, 19C, 20C, 21B
16	74LS245	15B, 15C
17	74LS374	1E, 1F, 5F, 12C, 16B, 16C, 16D, 16E, 17A, 17D, 17E,
18	TMM2016P-1	15A, 14A 13B, 13C
19	MC68000G8	9B
20	10.00000 MHZ	Y1
21	LM393	4A
22	AM2901CPC	12F, 13F, 14F, 15F
23	79L05	VR1
24	CD4051BE	1D, 3D
25	16.00000 MHZ	Y2
27	BATTERY	13A

COMPONENT REFERENCE LIST

ITEM NO.	DEVICE DESIGNATION	LOCATION
26	74S74	3F
28	330 OHMS	RL7, 18
29	RES. NETWORK 1K	RN5
30	RES. NETWORK 10 K	RN1-4
31	100 PF	C2
32	.1 MF	ALL LOCATIONS MARKED BY *
33	47 MF	C26
34	1500 PF	C6-13, C15-22
35	470 OHM	RL5, 16
36	1 K	R23, 24, 29, 30, 31
37	1 MEG	R1
38	2.2 K	R5, 7
39	3.3 K	RL9, 4, 6 (SEE REWORK INSTRUCTION)
40	10 K	R22 SEE REWORK INSTRUCTIONS
46	HM6117LP-3 (OR EQUIV. HM6116LP-3)	14B, 14C
47	10 MF	C3, 43
48	.02 MF	C4
49	4.7 MF	C5
50	6800 PF	C14, 23
51	1000 PF	C27, -42
52	18 PF	C1, 24
53	TL074CN (OR EQUIV. LF347N)	1B, 1C, 2B, 3B, 3C
54	74LS373	12A, 12B, 17B, 17C
55	82S185	16F, 17F, 18F, 19F
56	74LS138	6B, 6C, 11D, 13D, 14D, 15D
57	74LS05	5B, 9D 6, 0, 1

TITLE: Mother SoundsDWG. NO.: 010017 Rev. DSHEET 3 OF 3

COMPONENT REFERENCE LIST

ITEM NO.	DEVICE DESIGNATION	LOCATION
58	82S129	7E, 7F, 8E, 8F, 9E, 9F, 10E, 10F, 11E, 11F
59	AD752LJN	2D
60	SOCKET 18 PIN	16F, 17F, 18F, 19F
61	9.09 K \pm 1%	R20
62	10K \pm 1%	R2, 3, 21
63	LM336B	CR1
64	750 OHM	R25, R12, R13, R14
65	1N4002	(SEE REWORK INSTRUCTIONS)
66	RES NETWORK 100 OHM	A18, 19
67	RES NETWORK 220 OHM	A20
69	74LS14	5A, 21A
* 71	SOCKET 16 PIN	7E, 7F, 8E, 8F, 9E, 9F, 10E, 10F, 11E, 11F, D1, D2
72	TL072CP (OR EQUIV. LF353)	2C
73	100 OHMS	R8, 11
74	RES. NETWORK 3.3K	RN6, 7
75	FERRITE BEAD	L1
77	47 PF	C25
78	27 PF	SEE REWORK INSTRUCTIONS
**70	74S04	2F, 7A
79	SOCKET 64 PIN	9 B
80	SOCKET 40 PIN	12E, 13E, 14E, 15E
81	SOCKET 24 PIN	14A, 15A, 13B, 13C, 14B, 14C
82	74LS273	20B
83	10 K	(SEE REWORK INSTRUCTIONS)
84	74HC100	5E
85	180 OHM	R26
86	1N5817	CR2 (SEE REWORK INSTRUCTIONS)

TITLE: Rotate Video

DWG. NO.: 010029

Rev C

SHEET 1 OF 6

COMPONENT REFERENCE LIST

ITEM NO.	DEVICE DESIGNATION	LOCATION
2	74LS00	11J, 11M, 8K, 5N, 3H, 1C
3	74LS02	14J, 12N, 10K, 6F, 6J, 5M
4	74LS04	10L, 6L, 3J
5	74LS08	8M
6	74LS32	13J, 9K, 1D
7	74LS74	14K, 10M, 9L, 9M, 8N, 7L, 6H, 6K, 6M, 5K, 8J
8	74LS86	9J
9	74LS123	7N
10	74LS138	11A, 1A, 7K
11	74S139	12L
12	74LS145	3D, 3E, 2D, 2E, 1E
13	74LS151	10J
14	74LS157	11F
15	74LS161	10E, 9F, 8F, 7F
16	82S129	5H, 4H
17	74S175	13M
18	74LS175	4F, 5F
19	74LS244	12B, 11B, 11H, 5E, 3A
20	74LS245	8E, 7E
21	74LS253	14H, 13H
22	74LS629	4N
23	74LS374	11L, 10A, 10B, 10C, 10D, 9A, 9B, 9C, 9D, 9E, 8A, 8C, 8D, 7A, 7C, 7D, 6A, 5A, 4D, 4E, 2A
24	82S131	12C, 12D, 12E, 12F, 12H, 12J, 12K, 10F, 10H, 9H, 8H, 7H
25	TL071	4M

TITLE: Rotate/Video

DWG. NO.: 010029 Rev B

SHEET 2 OF 6

COMPONENT REFERENCE LIST

ITEM NO.	DEVICE DESIGNATION	LOCATION
26	TL074	3L, 2K
27	LM311	3K
28	POTENTIOMETER 2K	R27
29	3,579545 MHZ	Y1
30	2N3904	Q3, 4, 8, 9, 14, 17, 19
31	2N3906	Q1, 2, 5, 6, 7, 10, 11, 12, 16, 18
32	1N4148	CR1-5
33	TMM2016P-1	11C, 11D
34	AM2901CPC	14B, 14C, 14D, 14F
35	1MS2620P-15	6B, 6C, 5B, 5C
36	74LS393	14M, 10N, 6E, 5J, 4J
37	74LS05	1F
38	10.00000 MHZ	Y3
39	18PF	C124, 172
40	56PF	C98
41	.01MF	C107, 122, 129
42	1000 PF 5%	C145
43	4.7 MF TANTALUM	C181, 183, 186
44	22PF	C118
45	75 OHMS	R22, 77, 101, 109
46	560 OHMS	R41, 49, 90
47	330 OHMS	R68, 69, 87
48	390 OHMS	R88
49	1 MEG	R23
50	100 OHMS	R10-12
51	1K	R1-5, R21, R45, R52, R54, R63, R70-72, R93, R16-20

TITLE: Rotate/VideoDWG. NO.: 010029 Rev BSHEET 3 OF 6

COMPONENT REFERENCE LIST

ITEM NO.	DEVICE DESIGNATION	LOCATION
52	330K	R51
53	1.5K	R31, 53, 59
54	1.8K	R95
55	39K	R40
56	2.7K	R26, 96
57	10K	R24, 29, 37, 38, 42, 47, 55, 57, 61, 62, 65 (SEE REWORK INSTRUCTION)
58	27K	R56
59	56K	R36, 43
63	POTENTIOMETER 10K	R25, 35
66	74LS109	6N
67	74LS164	5L
68	74LS174	1B
69	SY2148H-3	3B, 3C, 2B, 2C
70	74LS221	7M
71	MM5321	4K
72	74LS390	9N
74	AM2857DC	4L
75	AN5310 (OR CN5310)	1M
76	33PF	C178
77	1000PF \pm 1%	C165, 167
78	4.7MF	C96, 106, 120
79	25MF	C111
80	.22MF	C114-116, 119
81	1MF	C164, 176
82	180PF	C125, 126
83	360PF	C112

TITLE: Rotate/Video

DWG. NO.: 010029 Rev B

SHEET 4 OF 6

COMPONENT REFERENCE LIST

ITEM NO.	DEVICE DESIGNATION	LOCATION
84	68PF	C117
85	27PF	C121
86	47PF	C108, 173
87	100PF	C113
88	82PF	C123
89	15 MH	L6, L7
90	33 MH	L5
91	47 MH	L4
92	2.2K	R48, 44
93	5.1K	R34, 58
94	84.5K \pm 1%	R66
95	147K \pm 1%	R67 (SEE REWORK INSTRUCTION)
96	16K	R64
97	3.3K	R28
98	20K	R114
99	POTENTIOMETER 5K	R30
100	POTENTIOMETER 1 MEG	R50
101	12 OHMS	R81, 105, 113
102	27 OHMS	R80, 104, 112
103	43 OHMS	R79, 103, 111
105	62 OHMS	R78, 102, 110
106	91 OHMS	R76, 100, 108
107	110 OHMS	R75, 99, 107
108	120 OHMS	R74, 98, 106
109	180 OHMS	R82
110	200 OHMS	R6-9, 83

TITLE: Rotate/Video

DWG. NO.: 010029 Rev C

SHEET 5 OF 6

COMPONENT REFERENCE LIST

ITEM NO.	DEVICE DESIGNATION	LOCATION
111	220 OHMS	R84
112	270 OHMS	R85
113	300 OHMS	R46, 86
114	470 OHMS	R32, 89
115	680 OHMS	R91
116	750 OHMS	R13-15, 73
117	820 OHMS	R92
118	1.3K	R94
119	5.6 K	R97
120	7.5K	R60
121	1K SIP	RPI, 2
122	2.2 MF	C109
123	18.88111 MHZ	Y2
124	7812	VRI
125	7912	VR2
127	74LS03	8L
128	74S74	13L, 12M
129	74S138	11K, 7J,
130	SOCKET 16 PIN	4H, 5H, 7H, 8H, 9H, 10F, 10H, 12C-12K, 4K, 4N
131	74S04	13N
132	100 MF	C100, 101
133	FERRITE BEAD	L1-3
134	FERRITE BEAD	BASE OF ALL TRANSISTORS
135	51 OHM DIP	RN3, 4
139	.1 MF	C4-95, 97, 99, 102-105, 110, 114-116, 119, 127, 128, 130, 133-144, 146-163, 166, 168-171, 174, 175, 179, 183, 185 (SEE REWORK INSTRUCTION)

TITLE: Rotate/Video

DWG. NO.: 010029 Rev B

SHEET 6 OF 6

COMPONENT REFERENCE LIST

ITEM NO.	DEVICE DESIGNATION	LOCATION
141	47 MF	C1-3
142	15K	R33
136	SOCKET 40 PIN	14B, 14C, 14D, 14F
137	SOCKET 28 PIN	1 M
138	SOCKET 24 PIN	11C, 11 D
143	SOCKET 18 PIN	2B,3B,2C,3C,5B,5C,6B,6C
144	74F245	4B,4C

TITLE: Line DrawerDWG. NO.: 010025 Rev BSHEET 1 OF 3

COMPONENT REFERENCE LIST

ITEM NO.	DEVICE DESIGNATION	LOCATION IN ()
2	74LS00	U60, U55, U62, (15D, 12L, 3E)
3	74LS02	U56, U24, U59, (11J, 3D, 1D)
4	74LS04	U26, U65, (13F, 4E)
5	74LS08	U61, (1J)
6	74LS257	U106, U105, (12J, 8L)
7	74LS32	U57, U23, (15F, 7F)
8	74LS74	U63, U50, U74, U45, U64, (15B, 15G, 5L, 2B, 1E)
9	74LS174	U72, U52, U73, (15E, 11K, 2F)
10	74LS85	U96, U95, (7L, 6L)
11	74LS86	U25, U58, (5C, 1F)
12	74LS283	U94, U93, (13G, 9L)
13	74LS138	U112, U42, U71, (6D, 2C, 2H)
14	74LS139	U113, U75, (7B, 4D)
15	74LS151	U43, (4C)
16	74LS153	U69, U68, U67, (15C, 4F, 1G)
17	74S04	U46, (14H)
18	74LS157	U84, U104, U100, U102, U101, U103, U86, U82, U85, U99, U83, (8D, 8F, 8G, 8H, 8J, 8K, 7E, 6C, 5J, 5I, 2D)
19	74LS161	U110, U32, U109, U37, U38, U47, U36, U33, (7K, 6K, 4A, 4B, 15K, 4G, 1B)
20	74LS164	U66 (1H)
21	74LS159	U81, U78, U76, U77, U80, U79, (9F, 7C, 5B, 5D, 4E, 2E)
22	74LS175	U51, (11L)
23	74S00	U54, (13E)
24	74LS244	U90, U91, U107, U118, U117, U114, U115, U116, U4 (14L, 13L, 12K, 9G, 8A, 8B, 8E, 7D, 3A)

TITLE: Line DrawerDWG. NO.: 010025 Rev BSHEET 2 OF 3

COMPONENT REFERENCE LIST

ITEM NO.	DEVICE DESIGNATION	LOCATION
25	74S74	U49 (15H)
26	74S138	U41, U70, (9B, 2K)
27	74LS374	U13, U14, U15, U16, U17, U89, U92, U22, U20, U18 U21, U19, U122, U119, U120, U123, U124, U87, U12 U88, (15A, 14A, 14B, 13A, 13D, 13H, 13J, 12A, 12 12C, 12D, 12E, 11A, 10A, 9A, 9C, 9D, 9E, 8C, 4H)
28	74LS393	U111, U108, (13K, 6J)
29	74S157	U39, U40, (5A, 2A)
30	HM6116P-3	U1, U3, U4, U2, (14C, 14D, 14E, 14G)
31	AM2901CPC	U11, U10, U12, (5E, 5G, 5H)
32	330 OHMS	R1, 2, 13
33	51 OHM DIP	U146-148, (12F, 11H, 10C)
34	750 OHM	R3
36	74S161	U35, U34, (1A, 7A)
37	.01 MF	C5-60
38	18PF	C1
39	50PF	C2
42	10.00000 MHZ	Y1
43	74S175	U48, (14K)
44	82S129	U5-9, U27-31, (3G, 2G, 3H, 3J, 3K, 6B, 3B, 3C, 2J)
45	1MS2620P-15	U144, U137, U143, U141, U135, U142, U139, U13, U138, U125, U129, U130, U126, U127, U133, U12, U131, (12G, 12H, 11B, 11C, 11D, 11E, 11F, 11G, 1 10B, 10D, 10E, 10F, 10G, 10H, 10J, 10K, 9H, 9J,
46	SY2148H-3	U98, U97, (7H, 7J)
47	74LS05	U149, (4K)
48	1K	R4-12
49	47MF	C3, C4

TITLE: Line Drawer

DWG. NO.: 010025 Rev B

SHEET 3 OF 3

COMPONENT REFERENCE LIST

ITEM NO.	DEVICE DESIGNATION	LOCATION
50	SOCKET 40 PIN	(5E, 5G, 5H)
51	SOCKET 24 PIN	(14C, 14D, 14E, 14G)
52	74S02	U53, (15J)
53	SOCKET 16 PIN	(3G, 2G, 3H, 3J, 3K, 6B, 3B, 3C, 3F, 2J)
54	390 PF	C61
55	010300 (HEADER ASSY-18 PIN)	U145

TITLE: F111

DWG. NO.: 010021 Rev: D

SHEET 1 OF 2

COMPONENT REFERENCE LIST

ITEM NO.	DEVICE DESIGNATION	LOCATION
2	74LS74	2M, 5M, 9M, 12M
3	74S151	4L, 7L, 11L, 14L
4	74LS161	3H, 3J, 3K, 6H, 6J, 6K, 8F, 10H, 10J, 10K, 13H, 13K
5	74LS244	1D, 3L, 6L, 10L, 13L
6	74LS374	2C, 3E, 3F, 4D, 5C, 6E, 6F, 7D, 9C, 10E, 10F, 11D, 12A, 12C, 13A, 13E, 13F, 14A, 14D
7	74S00	3N, 6N, 10N, 13N
8	74S85	2D, 2F, 2H, 2J, 3D, 5D, 5F, 5H, 5J, 6D, 9D, 9F, 9J, 10D, 12D, 12F, 12H, 12J, 13D
9	74S139	2L, 5L, 9L, 12L, 8L
10	82S129 (PROGRAMMED ROMS)	2P, 3P, 4P, 5P, 6P, 7P, 9P, 10P, 11P, 12P, 13P,
11	SY2148H-3	4E-4K, 7E-7K, 11E-11K, 14E-14K
12	74LS174	2E, 2K, 2N, 4N, 5E, 5K, 5N, 7N, 9E, 9K, 9N, 11N, 12E, 12K, 12N, 14N
13	.1MF	C1-10, C12-137, C139-151, C153-164
15	74S244	7A, 13C, 10C, 6C, 3C, 14B, 11B, 7B, 4B, 13B, 10E, 6B, 3B, 12B, 9B, 5B, 2B
19	74S04	3M, 6M, 8J, 8N, 10M, 13M
20	74S02	4M, 7M, 11M, 14M
21	1K, $\frac{1}{2}W \pm 5\%$	R1-7, R10-16
23	47MF, 35VDC	C11
25	560 OHM SIP	RP1-12

TITLE: F111

DWG. NO.: 010021 Rev D

SHEET 2 OF 2

COMPONENT REFERENCE LIST

ITEM NO.	DEVICE DESIGNATION	LOCATION
28	FERRITE BEAD	L1
29	74S74	8A, 8H
30	SOCKET 16 PIN	2P-7P, 9P-14P
31	74S374	4C, 7C, 11C, 14C
32	SOCKET 18 PIN	4E-4K, 7E-7K, 11E-11K, 14E-14K
33	SOCKET 20 PIN	4D, 7D, 11D, 14D



TITLE PRINTED WIRING BOARD
1/0 INTERFACE

DWG. NO. 010232

SHEET 1 OF 2

REV

A

ITEM NO.	QTY	DRAWING NUMBER	DESCRIPTION	REMARKS
1	1	010231	PWB - 1/0 INTERFACE	
2	2	CAK 8121-V3	SWITCH, PUSH BUTTON	51, 52
3	28	STACKPOLE 57-3425	FERRITE BEAD (OR 57-1423)	FBI THRU FB22
4	2		CAPACITOR, 100MF	C38, 39
5	2		CAPACITOR, CERAMIC, 50V	C36, 37
6	35	MURATA ELECTRIC REPRODUCIBLES	CAPACITOR, MONO. 1000PF AKLD	C1 THRU C35
7	4		RESISTOR, FXD, 1 MEG 1/4W ±5%	R3, R5, R13, R15
8	4		RES, FXD, 22K, 1/4W ±5%	R7, R9, R17, R19
9	4		RES, FXD, 47K, 1/4W ±5%	R6, R8, R16, R18
10	4		RES, FXD, 820-Ω, 1/4W ±5%	R21 THRU R24
11	5		RES, FXD, 1K, 1/4W ±5%	R1, R10, R11, R12, R1
12	2	41162-001-272	RES. NETWORK 2.7K X 5 DIP	RP2, RP3
13	1	41162-001-221	RES. NETWORK 220-Ω X 5 DIP	RP1
14	2	1N4001	DIODE, 50V	CR3, CR4
15	7	TIP-120	TRANSISTOR, POWER, NPN DARLINGTON	Q1 THRU Q5
16	1	HP HDSP4830	LED, DISPLAY	U1
17	1	LM3900	QUAD NOTON OP AMP	U2
18	1	74LS374	INTEGRATED CIRCUIT	U3
19	1	74LS257B	INTEGRATED CIRCUIT	U4
20	39	FOZ-09-1133	CONTACT, FEMALE P.C.	
21	1	03-09-1152	CONNECTOR, RECEPT. 15 PIN	J1
22	1	03-09-1094	CONNECTOR, RECEPT 9 PIN	J2
23	1	03-09-1064	CONNECTOR, RECEPT 6 PIN	J5
24	1	03-09-1049	CONNECTOR, RECEPT 4 PIN SQ.	J3
25	1	03-09-1032	CONNECTOR, RECEPT 3 PIN	J6
26	1	03-09-1022	CONNECTOR, RECEPT. 2 PIN	J4
27	1	09-75-1138	CONNECTOR, R.A. 13 PIN	J7

TITLE PRINTED WIKING HOOT -
I/O INTERFACE



ITEM NO.

QTY

DRAWING NUMBER

DESCRIPTION

34 3433-1303 ^{OR EQUIV} CONNECTOR, R.A. 50 PIN RIBBON

D 010233 LOGIC DIAGRAM - I/O INTERFACE

later SPECIFICATION, TEST.

18



TITLE PWA AUDIO AMPLIFIER

DWG. NO. A010033
 SHEET 1 OF 1

RE Z

ITEM NO.	QTY	DRAWING NUMBER	DESCRIPTION	REMARKS
1	1	010032	PWB AUDIO AMPLIFIER	
2	2		CAP, ELECTROLYTIC .47MF, 25WVDC ±10%	
3	6		CAP, ELECTROLYTIC 10MF, 25WVDC ±10%	
4	1		CAP, CERAMIC, .047MF, 50V	
5	6		CAP, CERAMIC .1MF, 25WVDC ±10%	
6	5		RES, FXD, 33K 1/4W, ±5%	
7	3		RES, FXD, 33K 1/4W ±5%	
8	2		RES, FXD, 22K 1/4W ±5%	
9	3		CAP, CERAMIC .22 MF, 25WVDC ±10%	
10	3		RES, FXD 1 Ω 1/4W ±5%	
11	6	1N4002	DIODE	
12	2		CONNECTOR, 6 PIN (MOLEX 09-75-1068)	
13	1		CONNECTOR, 7 PIN (MOLEX 09-75-1078)	
14	1	010139	HEAT SINK	
15	REF	010034	ELECTRICAL SCHEMATIC - AUDIO AMPL	
16	1		CAP, CERAMIC 500PF-1000PF, 50V	
17	3	LM1875T	POWER AUDIO AMPLIFIER 20WATT	
18	3	TDA 2030V	POWER AUDIO AMPLIFIER 20WATT	
19	2		SCREW, PAN HD, PHIL. #6-32X 1/2LG	STAINLESS STEEL
20	2		SPACER, 1/4 DIA, #6 CLEAR X 1/4LG.	
21	4		SPACER, NYLON	(RICHCO SR56-BN)
22	2		RES, FXD, 68K, 1/4W ±5%	
23	1		RES, FXD, 91K, 1/4W ±5%	
24	3		SCREW, PAN HD, PHIL. #6-32X 1/4 LG	
25	2		CAPACITOR, CERAMIC, .02MF 50V	

SPECIFICATIONS

INPUT: 105 to 125 VAC or 210 to 250 VAC at 47 to 63 Hz. Derate output current 10% for 50 Hz operation.

DC OUTPUT RATINGS: See Voltage/Current Rating Chart.

REGULATION: Line regulation is rated at 0.05% for a 10% input voltage change and load regulation is rated at 0.1% for a zero to full load change.

OUTPUT RIPPLE: Better than 1 mV RMS; 3 mV peak to peak typical.

OVERLOAD PROTECTION: Self restoring current limiting (foldback type) is standard.

OVERVOLTAGE PROTECTION: All 5-Volt output models with a V suffix are provided with built-in OVP as a standard feature. The OVP circuit is preset at 6.2 ± 0.4 Volts.

TEMPERATURE COEFFICIENT: ± 0.005%/°C typical. ± 0.02%/°C maximum.

COOLING: Convection cooled. Moving air is recommended when mounting in a confined area.

MOUNTING: The open frame mounts on any one of four surfaces.

OUTPUT VOLTAGE ADJUSTMENT: The output of all EconoMate II power supplies may be adjusted by means of a potentiometer located on the printed circuit board. The potentiometer is labeled "EO ADJ.". During the adjustment procedure, monitor the DC output voltage by connecting a meter across the output terminals.

INPUT CONNECTIONS: When operating with 115 VAC input, place a jumper between transformer terminals one (1) and two (2) and also between three (3) and four (4). Then connect the AC primary leads to terminals one (1) and four (4) as shown in Fig. 1. When operating with 230 VAC input, place a jumper between transformer terminals two (2) and three (3) and connect the AC primary leads to terminals one (1) and four (4) as shown in Fig. 2.

SECONDARY TRANSFORMER CONNECTIONS: On certain models it will be necessary to connect the transformer secondary to the PC board before adjusting the output voltage. This is accomplished by soldering the loose wire attached to the PC board to the appropriate tap on the transformer.

LOCAL SENSING: ECONOMATE II power supplies are factory wired for local sensing. Sensing terminals are located on the PC board. A jumper connecting the DC output and sensing terminals provides local sensing as shown in Fig. 3.

REMOTE SENSING: Remote sensing is a standard feature. To sense the output voltage directly at the load, disconnect the jumpers between the DC output terminals and sensing terminals. Connect the load to the DC output terminals. Then wire the (+) and (-) sensing terminals respectively across the load as shown in Fig. 4. This permits sensing directly at the load.

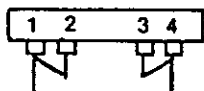

Fig. 1

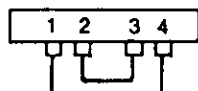

Fig. 2

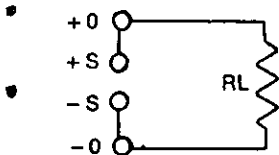

Fig. 3

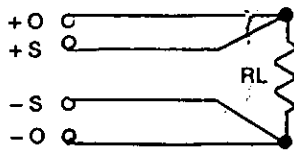

Fig. 4

OUTPUT CONNECTIONS

Positive and negative output terminals are marked and located on printed circuit boards. No connection is necessary for 5/6 or 24-volt outputs. 12/15 volt outputs have secondary leads which must be soldered to the appropriate transformer taps according to the output voltage required, as indicated in the following table:

SERIES	OUTPUT VOLTAGE	OUTPUT A TAP NO.	OUTPUT B TAP NO.
ETA-D	12V	6	9
	15V	7	10

No connection is necessary for 5/6 or 24-volt outputs.

SCHEMATIC FIG. # 5

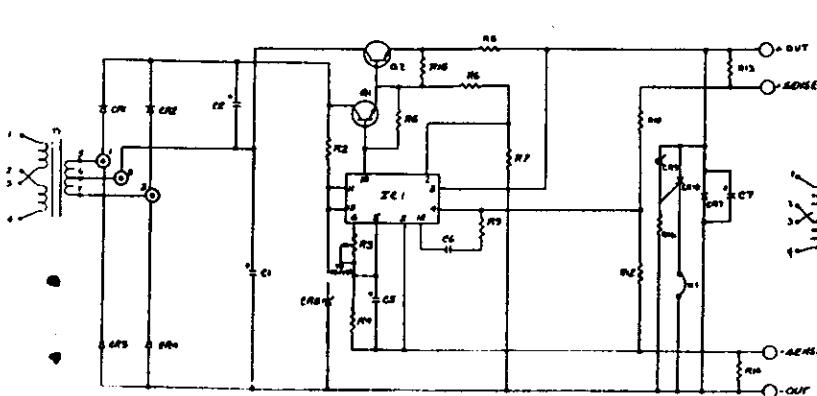

DUAL OUTPUT POWER MODELS

MODEL	OUTPUT "A"	SCHEM. FIG.#	OUTPUT "B"	SCHEM. FIG.#	*PARTS LIST COLUMNS
ETA-5DV	5V-6.0A	5	5V-6.0A	5	A and A
ETA-515DV	5V-6.0A	5	15V-2.8A or 12V-3.0A	6	A and B
ETA-12/15D	12V-3.0A or 15V-2.8A	6	12V-3.0A or 15V-2.8A	6	B and B
ETA-524DV	5V-6.0A	5	24V-2.3A	6	A and C

*Reference Parts List below for separate PCB components.

SCM. REF.	PMC PART NO.	A	B	C	DESCRIPTION	SCM. REF.	PMC PART NO.	A	B	C	DESCRIPTION
C1	CE223015	1			CAP. 22000 MFD, 15V	R4	RC334800	1			RES 3.48K OHMS, 1/4
C1	CE682035	1			CAP. 6800 MFD, 35V	R5	RB227200	1	1	1	RES 2.7K OHMS, 1/4W
C1	CE147263		1		CAP. 4700 MFD, 50V	R6	RB212100	1			RES 120 OHMS, 1/4W
C2, 7	CE410800	2			CAP. 1000 MFD, 16V	R6	RB210100	1			RES 100 OHMS, 1/4W
C3, 4, 7	CE233700		3		CAP. 330 MFD, 35V	R6	RB262100		1		RES 620 OHMS, 1/4W
C3, 4, 7	CE825700		3		CAP. 220 MFD, 50V	R7	RB243100	1			RES 430 OHMS, 1/4W
C5	CE047350	1	1	1	CAP. 4.7 MFD, 35V	R7	RB210200	1			RES 1K OHMS, 1/4W
C6	CD310200	1	1	1	CAP. 0.001 MFD, 500V	R7	RB212300		1		RES 12K OHMS, 1/4W
CR1, 2	DR003000		2		DIODE 1 AMP 200V	R8	RF050000	1			RES 0.05 OHM, 3W
CR1-4	DR039000		4	4	DIODE 5 AMPS 100V	R8	RF200150	1			RES 0.15 OHM, 3W
CR3, 4	DR085000		2		DIODE 1 AMP 240V	R8	RE200240		1		RES 0.24 OHM, 2W
CR5, 6	DR003000		2	2	DIODE 1 AMP 240V	R9	RB233200	1	1	1	RES 3.3K OHMS, 1/4W
CR7	DR039000	1	1	1	DIODE 5 AMPS 100V	R10	RC386600	1			RES 866 OHMS, 1/4W
CR8	DZ211600	1	1		DIODE 1N4752A	R10	RF220201	1	1		POT. 2K OHMS, 20%
CR9	DZ231000	1			DIODE 1N752A	R11	RC310200				RES 1K OHMS, 1/4W
CR10	DS048000	1			SCR 2N4441	R11	RC315001	1			RES 1.5K OHMS, 1/4W
IC1	QK026300	1	1	1	INT-CIR 723	R12	RC320500	1			RES 2.05K OHMS, 1/2
Q1	QP001300	1			XTOR 2N3055	R12	RC311500		1		RES 1.15K OHMS, 1/2
Q1	QS055000	1	1	1	XTOR 2N2102	R13, 14	RB210000	1	1	1	RES 10 OHMS, 1/4W
Q2	QP001300	1	1	1	XTOR 2N3055	R15	RB210100	1			RES 100 OHMS, 1/4W
R1	RF210100	1			RES 100 OHMS, 3W, 5%	R15	RB216100		1		RES 180 OHMS, 1/4W
R1	RE222100		1		RES 220 OHMS, 2W, 10%	R15	RB222100		1		RES 220 OHMS, 1/4W
R2	RC215100	1			RES 150 OHMS, 1/4W, 10%	T1	TA2826602				TRANSFORMER ETA
R2	RC227100	1			RES 270 OHMS, 1/4W, 10%	T1	TA2826601				TRANSFORMER ETA
R2	RF215200	1			RES 1.5K OHMS, 3W, 5%	T1	TA2826603				TRANSFORMER ETA
R3	PF220201	1			POT. 2K OHMS, 20%	T1	TA2826604				TRANSFORMER ETA
R3	RC311500	1	1		RES 1.15K OHMS, 1/4W, 1%						

NOTE: Reference "Dual Output Power Models" chart above for appropriate combination of two PCB's for each ETA-D model.

SCHEMATIC FIG. # 6

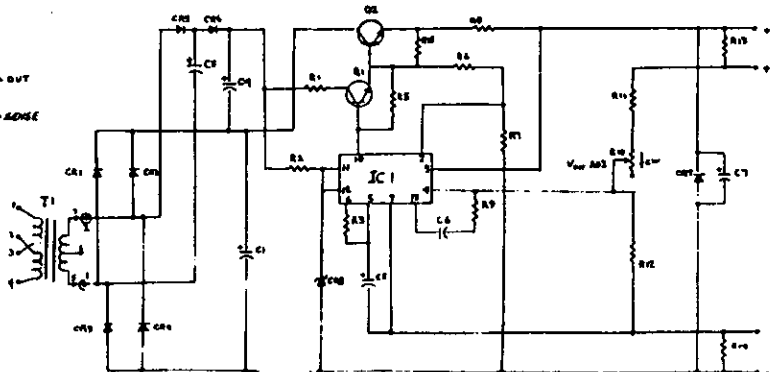



SPECIFICATIONS

- AC Input:** 85-to-132 or 170-to-264 VAC, at 47-440 Hz.
- DC Output:** See voltage and current rating chart.
- DC Output Adjustment:** ± 10 percent.
- Regulation:** Line, ± 0.1 percent, +1mV within the specified AC limits. Load, ± 0.1 percent, +1mV from no-load to full-load conditions.
- Noise and Ripple:** 50mV peak-to-peak maximum, 20Hz to 20MHz
- Efficiency:** 70-to-80 percent.
- Transient Response:** Recovery to 1.0 percent in 300 microseconds for a 50-to-100 percent load change.
- Remote or Local Sensing:** A provision is included for improved overall regulation.
- Overload and Short-Circuit Protection:** Solid-state short-circuit protection is a standard feature. An automatic current-limiting circuit limits the output current which provides protection for the load and supply. Units cannot be damaged by prolonged short circuits.
- Overshoot:** No voltage spikes on turn-on, turn-off, or during power failure.
- Logic Inhibit Function:** A 4.5 to 5.5. VDC command signal, referenced to the negative sense terminal, will inhibit the DC output. It may be used for control, sequencing, or maintenance.
- Enable Function (optional):** A command signal less than 0.8 VDC will turn supply off. A command signal greater than 2.5 VDC will turn supply on.
- Over-Voltage Protection:** Built-in, fixed.
- Energy-Storage Time:** The output voltage will remain within the regulation range for a minimum of 16 ms after the loss of AC power (from nominal line voltage).
- Polarity:** Positive, negative, or floating up to 300VDC.
- Soft Start:** Provides input current limiting at turn on.
- Parallel Operation:** Units may be paralleled for increased output current. Consult the factory for the proper procedures.
- Long-Term Stability:** 0.1 percent for 8 hours after a 20 minute warm up.

Ambient Operating Temperature: Continuous duty from 0 to +71°C, full rating from 0 to +50°C. Derate linearly to 60 percent of full rating at +71°C.

Storage Temperature: -55°C to +85°C.

Quality Control: In accordance with MIL-I-45208.

OPERATING INSTRUCTIONS

AC INPUT

Normally, the unit is shipped for 115 VAC input operation. If 230 VAC input is desired, cut jumper W1 on PC board shown in Fig. 1.

SENSING TERMINALS

For local sensing the supply can be used as delivered. For remote sensing, connect the load to the DC output terminals. Then wire the (+) and (-) sensing terminals respectively across the load. This permits sensing directly at the load. See Fig. 2.

VOLTAGE AND CURRENT ADJUSTMENTS

The voltage adjustment (VR2) is a precision multi-turn potentiometer which is accessible from the terminal end of the unit. The current adjustment potentiometer is factory set and no further adjustment is required.

COVERS

Covers for the ES units are included.

Power/Mate power supplies are designed for convection cooling, therefore, it's important not to impede the air flow across or through the power supply's case. Impeding the flow of air through your power supply may shorten its life. If there is doubt about the convection air flow through your Power/Mate supply's heat generating components, it's recommended that you use a small fan to insure satisfactory air flow.

CAUTION: High-voltage circuits present an electrical shock hazard. Do not handle the unit while it is operating.

ES-G Series

MODEL	VOLTAGE	CURRENT
ES-5G	5 VOLTS	30 AMPS
ES-12G	12 VOLTS	15 AMPS
ES-15G	15 VOLTS	12 AMPS
ES-24G	24 VOLTS	8 AMPS
ES-28G	28 VOLTS	7 AMPS
ES-36G	36 VOLTS	5 AMPS

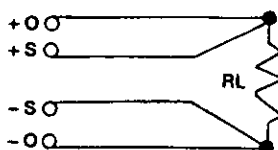

FIG. 2

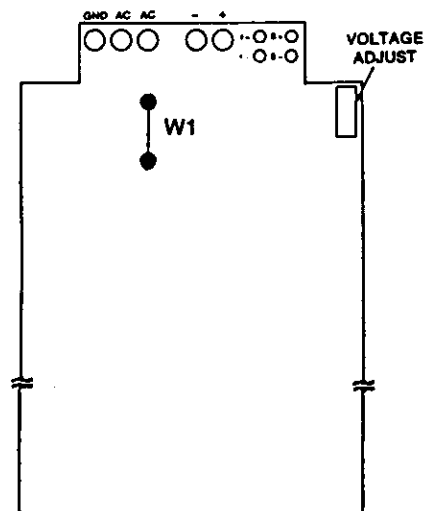

FIG. 1